



Classified by Underwriters Laboratories, Inc. to UL 2079 and CAN/ULC-S115

# System No. HW-D-0640

HWD 0640

ANSI/UL2079	CAN/ULC S115
Assembly Rating — 1 and 2 Hr (See Item 2)	F Rating — 1 and 2 Hr (See Item 2)
Nominal Joint Width - 1-1/2 In.	FT Rating — 1 and 2 Hr (See Item 2)
Class II Movement Capabilities — 50% Compression or Extension	FH Rating — 1 and 2 Hr (See Item 2)
	FTH Rating — 1 and 2 Hr (See Item 2)
	Nominal Joint Width - 1-1/2 In.
	Class II Movement Capabilities — 50% Compression or Extension

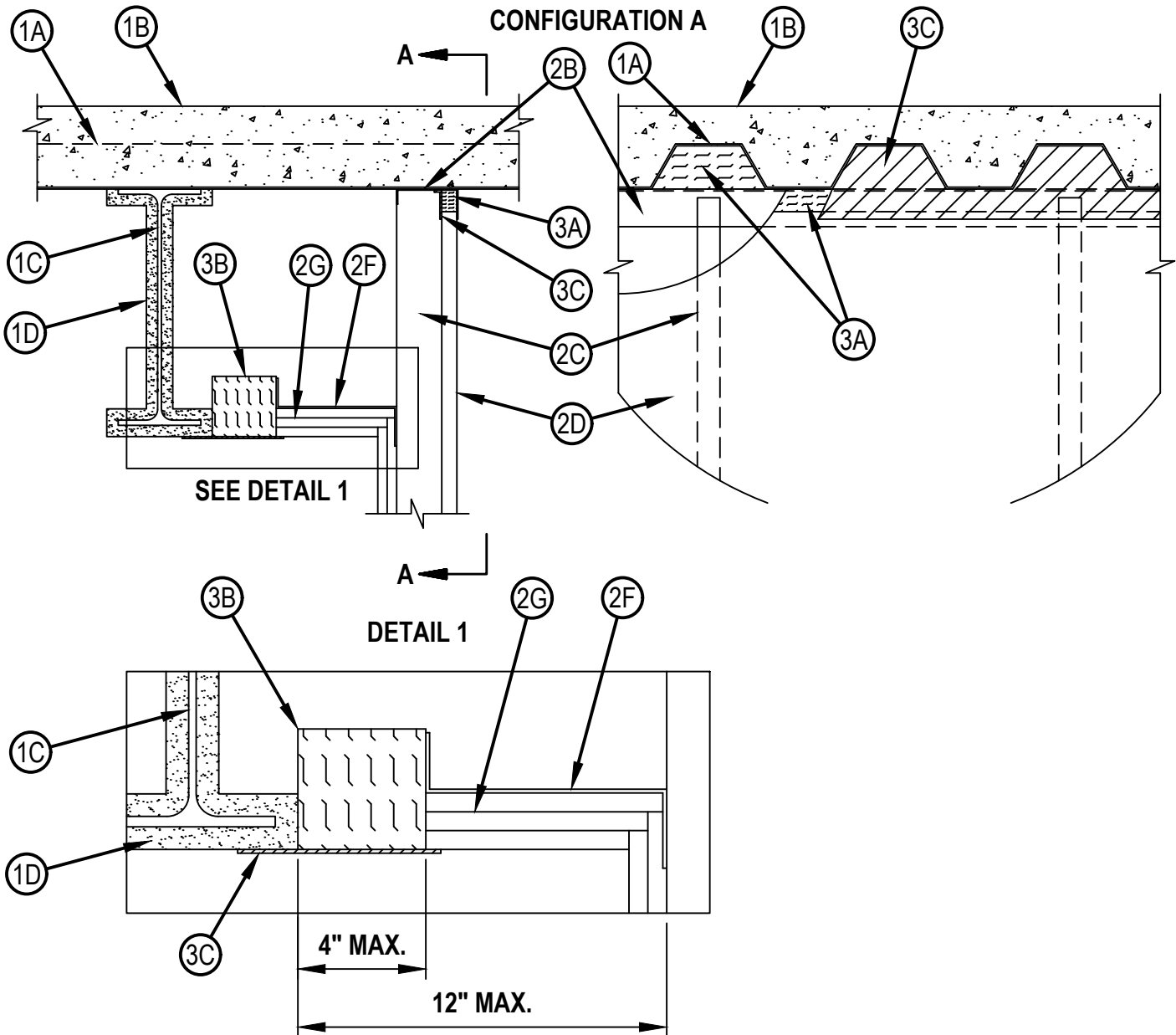

Reproduced by HILTI, Inc. Courtesy of Underwriters Laboratories, Inc. June 22, 2023

CONFIGURATION B

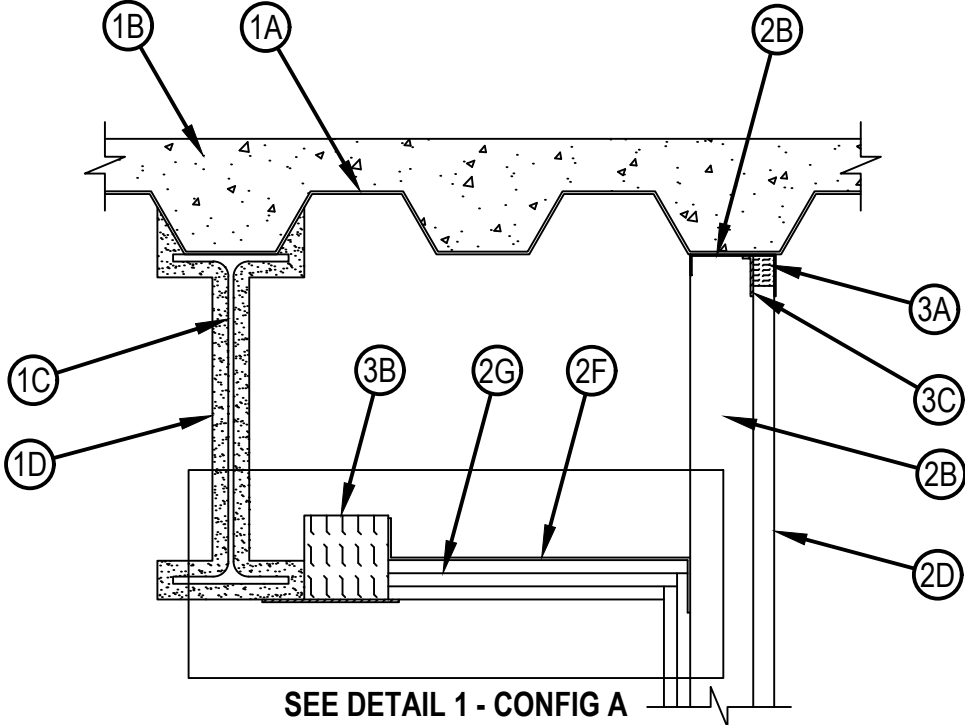

1. Floor Assembly — The fire-rated fluted steel deck/concrete floor assembly shall be constructed of the materials and in the manner described in the individual D700 or D900 Series Floor-Ceiling Design in the UL Fire Resistance Directory. The hourly fire rating of the floor assembly shall be equal to or greater than the hourly fire rating of the wall assembly. The floor assembly shall include the following construction features:
  - A. Steel Floor and Floor Units\* — Max 3 in. (76 mm) deep galv steel fluted floor units.
  - B. Concrete — Min 2-1/2 in. (64 mm) thick reinforced concrete, as measured from the top plane of the floor units.
  - C. Structural Steel Support — Steel beam or open-web steel joist as specified in the individual D700 or D900 Series Floor-Ceiling Design, used to support steel floor units. Structural steel support oriented parallel to wall assembly at a distance specified in Item D below. When structural steel support (Item 1C) consists of open-web steel joists, 3/8 in. (10 mm) diamond mesh expanded steel lath having a nom weight of 1.7 to 3.4 lb per sq yd (0.9 to 1.8 kg/m<sup>2</sup>) shall be installed to completely cover one side of each joist. The lath shall be secured with steel tie wire and shall be fully covered with spray applied fire resistive material.
  - D. Spray-Applied Fire Resistive Material\* — Structural steel supports to be sprayed with the thickness of material specified in the individual D700 or D900 Series Design. The flutes of the steel floor units above the structural steel supports shall be filled with spray-applied fire resistive material. The distance from the sprayed structural steel support to the face of the steel wall studs shall not exceed 12 in. (305 mm).  
GCP APPLIED TECHNOLOGIES INC — Type MK-6/HY, MK-6/HY ES, MK-6s, MK-10HB, RG  
ISOLATEK INTERNATIONAL — Type 300
  - E. Spray-Applied Fire Resistive Material\* — (Not Shown) - For D700 Series Floor-Ceiling Design, after installation of the ceiling runner (Item 2A), steel floor units to be sprayed with the thickness of material as specified in the individual D700 Series Design. The flutes of the steel floor units above the ceiling runner (Item 2A) shall be filled with spray-applied fire resistive material. As an alternate, the spray-applied fire resistive material in the flutes above the ceiling runner may be applied to follow the contour of the steel floor units. Excess material shall be removed from the flanges of the ceiling runner beyond the required thickness of spray-applied fire resistive material on the steel floor units.  
GCP APPLIED TECHNOLOGIES INC — Type MK-6/HY, MK-6/HY ES, MK-6s, MK-10HB, RG  
ISOLATEK INTERNATIONAL — Type 300
2. Shaft Wall Assembly — The 1 hr or 2 hr fire rated gypsum board/steel stud shaft wall assembly shall be constructed of the materials and in the manner described in the individual U400 or V400 Series Wall and Partition Design in the UL Fire Resistance Directory and shall include the following construction features:
  - A. Floor and Wall Runners — (Not Shown) - J-shaped runner, equal in width to steel studs (Item 2C), with unequal legs of 1 in. (25 mm) and 2 in. (51 mm), fabricated from 24 MSG galv steel. Runners positioned with short leg toward finished side of wall. Runners attached to floor with steel masonry anchors, steel fasteners or welds located not greater than 2 in. (51 mm) from ends and not greater than 24 in. (610 mm) OC before or after optional spray-applied fire resistive material is used. The use of welds to secure the ceiling runner may only be used prior to the installation of the optional spray-applied material.
  - B. Ceiling Runner — Ceiling runner of wall assembly shall consist of galv steel channel sized to accommodate steel studs (Item 2C). Flange height of ceiling runner shall be min 1/4 in. (6 mm) greater than max extended joint width. Ceiling runner installed perpendicular or parallel to direction of fluted steel deck and parallel to structural member and secured to steel deck valleys with steel masonry anchors, steel fasteners or welds spaced max 24 in. (610 mm) OC before or after optional spray-applied fire resistive material is used. The use of welds to secure the ceiling runner may only be used prior to the installation of the optional spray-applied material.
  - B1. Light Gauge Framing\* - Slotted Ceiling Runner — As an alternate to the ceiling runner in Item 2B, slotted ceiling runner to consist of galv steel channel with slotted flanges sized to accommodate steel studs (Item 2C). Flange height of slotted ceiling runner shall be min 1/4 in. (6 mm) greater than max extended joint width. Slotted ceiling runner installed perpendicular to or parallel direction of fluted steel deck and secured to steel deck valleys with steel masonry anchors, steel fasteners or welds spaced max 24 in. (610 mm) OC before or after optional spray-applied fire resistive material is used. The use of welds to secure the ceiling runner may only be used prior to the installation of the optional spray-applied material.



BRADY CONSTRUCTION INNOVATIONS INC, DBA SLIPTRACK SYSTEMS — SLP-TRK, SLPTRK325  
CEMCO, LLC — CST, CST325  
CLARKDIETRICH BUILDING SYSTEMS — Type SLT, SLT-H  
RAM SALES L L C — RAM Slotted Track  
SCAFCO STEEL STUD MANUFACTURING CO — Slotted Track  
TELLING INDUSTRIES L L C — True-Action Deflection Track

B2. Light Gauge Framing\* — Slotted Ceiling Runner — As an alternate to the ceiling runner in Item 2B through B1, slotted ceiling runner to consist of galv steel channel, sized to accommodate steel studs (Item 2C). Flange height of slotted ceiling runner shall be 3-1/4 in. (83 mm) with 2 in. (51 mm) deep slots. Slotted ceiling runner installed perpendicular to or parallel direction of fluted steel deck and secured to steel deck valleys with steel masonry anchors, steel fasteners or welds spaced max 24 in. (610 mm) OC before or after optional spray-applied fire resistive material is used. The use of welds to secure the ceiling runner may only be used prior to the installation of the optional spray-applied material.

SCAFCO STEEL STUD MANUFACTURING CO — Slotted Track-Type SDLT

C. Steel Studs — C-H or E-shaped studs, min 4 in. (102 mm) wide by 1-1/2 in. (38 mm) deep, fabricated from 25 MSG galv steel, cut to lengths 1 in. (25 mm) less than floor to ceiling height and spaced 24 in. (610 mm) OC. When slotted ceiling runner specified in Item 2B2 is used the C-H-shaped studs cut in lengths 3/4 to 1-3/4 in. (19 to 44 mm) less than floor to ceiling height and spaced 24 in. (610 mm) OC.

D. Gypsum Board\* — Nom 1 in. (25 mm) thick gypsum board liner panels. Panels cut 1-1/2 in. (38 mm) less in length than floor to ceiling height. Vertical edges inserted in H-shaped section of C-H or E studs. At the ends of the assembly, the free edge of the end panels are attached to the long leg of vertical J-runners (Item 2A) with 1-5/8 in. (41 mm) long Type S steel screws spaced max 12 in. (305 mm) OC.

E. Gypsum Board\* — Nom 5/8 in. (16 mm) thick gypsum board applied in one or two layers for 1 hr and 2 hr fire rated assemblies, respectively. This gypsum board on the finished side of wall shall extend to a height nominally flush with the lowest elevation of the structural steel support, with the top edge of the layers staggered as shown in the detail and such that the gypsum board attachment screws at top edge of board penetrate into Z-furring (Item F). The screws attaching the gypsum board layers to the C-H studs shall be located 1 to 1-1/2 in. (25 to 38 mm) below the bottom of the ceiling runner or slotted ceiling track. No gypsum board attachment screws are to penetrate the ceiling runner or slotted ceiling track.

F. Z-Furring — Min 2 x 4 x 2 in. (51 by 102 by 51 mm) to max 2 x 8 x 2 in. (51 by 203 by 51 mm) by min 20 ga steel Z-furring shelf continuous along length of joint on structural member side of wall. Located nominally 1-1/4 in. (32 mm) (1 hr fire rated assembly) or 1-7/8 in. (48 mm) (2 hr fire rated assembly) above lowest elevation of sprayed structural member. The horizontal gap between edge of Z furring shelf and sprayed structural member at lowest elevation shall be min. 1/2 in. (13 mm) to max 4 in. (102 mm). Z furring secured to each wall stud on structural member side of wall with one min No. 8 sheet metal screw located nom 1/2 in. (13 mm) from top of furring leg. At splices, adjoining sections of Z furring shall overlap nom 4 in. (102 mm) and be secured at approx center of lap with two min No. 8 sheet metal screws located max 2 in. (51 mm) from each lip of the furring shelf.

G. Gypsum Board\* — Gypsum board sheets of the same type and thickness as used on the finished side of wall shall be cut to size and installed to a min total 1-1/4 in. (32 mm) or 1-7/8 in. (48 mm) thickness to fully cover exposed bottom of steel furring shelf (Item F) for 1 and 2 hr fire rated assemblies, respectively. The mating edges of the gypsum board on the wall and furring shelf shall be cut to fit as shown in the detail. Joints in the layers of gypsum board shall be staggered. The inner two layers of gypsum are secured with two rows of drywall screws located 12 in. (305 mm) on center. The outer layer of gypsum board is secured with two rows of drywall screws located 8 in. (203) on center. All fasteners are staggered between layers and are of sufficient length to penetrate into the furring shelf.

The hourly fire rating of the joint system is equal to the hourly fire rating of the wall.

3. Joint System — Max separation between bottom of the steel floor units (or bottom of the spray applied fire resistive material on the steel floor units) and top of gypsum board liner panels (at time of installation of joint system) is 1-1/2 in. (38 mm). Max horizontal separation between spray applied fire resistive material on structural support member and Z-furring shelf is 4 in. (102 mm). The joint system is designed to accommodate a max 50 percent compression or extension from its installed width as measured between the bottom plane of the steel floor units or spray-applied fire resistive material on the steel floor units and the top of the gypsum board liner panels. The joint system shall consist of forming and fill materials, as follows:



A. Forming Material\* — Nom 1 in. (25 mm) thick strips of min 4 pcf (64 kg/m<sup>3</sup>) mineral wool batt insulation. On shaft side of wall, strips of mineral wool cut to width, compressed 50 percent in thickness and inserted cut-edge first within ceiling runner above the top of liner panel flush with the inside surface of liner panel. Adjoining lengths of batt to be tightly butted with butted seams spaced min 36 in. (914 mm) apart along the length of the joint. In addition, in D900 Series assemblies, and in D700 assemblies when the spray-applied fire resistive material in the flutes above the wall follows the contour of the steel deck, sections of mineral wool batt sized to attain a min compression rate of 50 percent in the thickness direction are firmly packed to completely fill the flutes of the steel floor or roof deck between the top of the ceiling runner and the steel deck or spray-applied fire resistive material. The mineral wool batt insulation in the flutes is to be installed flush with the gypsum board surface on the shaft side of the wall, and flush with the flange of the ceiling runner on the opposite side of wall.

INDUSTRIAL INSULATION GROUP L L C — MinWool-1200 Safing

JOHNS MANVILLE — Safing

ROCK WOOL MANUFACTURING CO — Delta Board

ROCKWOOL MALAYSIA SDN BHD — SAFE

ROCKWOOL — SAFE

THERMAFIBER INC — Type SAF

A1. Forming Material\* — Plugs — As an alternate to Item 3A for the fluted area of steel floor or deck, preformed mineral wool plugs, formed to the shape of the flutes, are friction fit to completely fill the flutes above the ceiling runner. The plugs shall be installed flush with wall surface on shaft side of wall, and flush with leg of ceiling runner on structural member side of wall. Additional forming material, described in Item 3A2, to be used in conjunction with the plugs to fill the gap within the ceiling runner above the top of gypsum board liner panel.

HILTI CONSTRUCTION CHEMICALS, DIV OF HILTI INC — CP777 Speed Plugs

A2. Forming Material\* - Strips — Nom 1-1/4 in. (32 mm) wide precut mineral wool strips. The strips are cut to appropriate thickness, compressed 50 percent in thickness and firmly packed within the ceiling runner into the gap above the gypsum board liner panel, flush with inside surface of liner panel.

HILTI CONSTRUCTION CHEMICALS, DIV OF HILTI INC — CP 767 Speed Strips

B. Forming Material\* — On structural member side of wall, pieces of min 4 pcf (64 kg/m<sup>3</sup>) mineral wool batt insulation cut to a width of 4 in. (102 mm), compressed 50 percent in thickness and inserted cut-edge first into gap between Z-furring/gypsum board shelf and lower elevation of sprayed beam, to be nominally flush with the bottom surface of this joint. Adjoining lengths of batt to be tightly butted with butted seams spaced min 36 in. (914 mm) apart along the length of the joint.

INDUSTRIAL INSULATION GROUP L L C — MinWool-1200 Safing

JOHNS MANVILLE — Safing

ROCK WOOL MANUFACTURING CO — Delta Board

ROCKWOOL MALAYSIA SDN BHD — SAFE

ROCKWOOL — SAFE

THERMAFIBER INC — Type SAF

C. Fill, Void or Cavity Material\* — Sealant — Min 1/16 in. (1.6 mm) dry thickness (1/8 in. or 3.2 mm wet thickness) of fill material sprayed or troweled within stud cavity and on both sides of the shaft wall to completely cover mineral wool forming material. Fill material to overlap a min of 1/2 in. (13 mm) onto gypsum board and ceiling runner within stud cavity. Fill material to overlap a min of 1/2 in. (13 mm) onto gypsum board and min 2 in. (51 mm) onto spray-applied fire resistive material on structural member on finished side of wall. Fill material in flutes to overlap a min of 1/2 in. onto steel deck and ceiling runner on unfinished side of wall with no overlap onto gypsum liner panel. When spray-applied fire resistive material (Item 1C) is applied to the steel deck, the fill material is to overlap the spray-applied fire resistive material a min of 2 in. (51 mm) on unfinished side of wall.

HILTI CONSTRUCTION CHEMICALS, DIV OF HILTI INC — CP672 Firestop Spray or CFS-SP WB Firestop Joint Spray

\* Indicates such products shall bear the UL or cUL Certification Mark for jurisdictions employing the UL or cUL Certification (such as Canada), respectively.

