



Classified by
Underwriters Laboratories, Inc.
to UL 2079 and CAN/ULC-S115

System No. BW-S-0001

BWS 0001

ANSI/UL2079	CAN/ULC S115
Assembly Ratings — 1 and 2 Hr (See Item 2)	F Ratings — 1 and 2 Hr (See Item 2)
Nominal Joint Width - 3/4 In.	FT Ratings — 1 and 2 Hr (See Item 2)
L Rating at Ambient — Less than 1 CFM/Lin Ft	FH Ratings — 1 and 2 Hr (See Item 2)
L Rating at 400° F — Less than 1 CFM/Lin Ft	FTH Ratings — 1 and 2 Hr (See Item 2)
	Nominal Joint Width - 3/4 In.
	L Rating at Ambient — Less than 1 CFM/Lin Ft
	L Rating at 400° F — Less than 1 CFM/Lin Ft

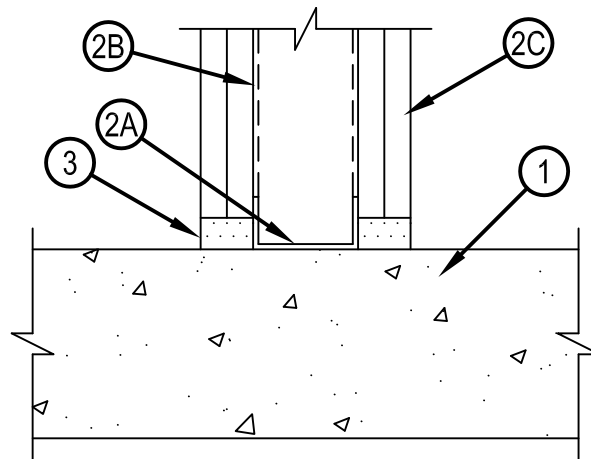

1. Floor Assembly — Min 4-1/2 in. (114 mm) thick reinforced lightweight or normal weight (100-150 pcf or 1600-2400 kg/m³) structural concrete. Floor may also be constructed of any 6 in. (152 mm) thick UL Classified hollow-core Precast Concrete Units*. See Precast Concrete Units category in the Fire Resistance Directory for names of manufactures.
2. Wall Assembly — The 1 or 2 h fire-rated gypsum board/steel stud wall assembly shall be constructed of the materials and in the manner specified in the individual U400 or V400 Series Wall or Partition Design in the UL Fire Resistance Directory. In addition, the wall may incorporate a head-of-wall joint system constructed as specified in the HW Series Joint Systems in the UL Fire Resistance Directory. The wall shall include the following construction features:
 - A. Steel Floor Runner — Floor runners of wall assembly shall consist of min No. 25 gauge galv steel channels sized to accommodate steel studs (Item 2B). Floor runners to be provided with min 1-1/4 in. (32 mm) flanges. Runners secured with steel fasteners spaced 12 in. (305 mm) OC.
 - B. Studs — Steel studs to be min 2-1/2 in. (64 mm) wide. Studs cut 1/2 to 3/4 in. (13 to 19 mm) less in length than assembly height with bottom nesting in, resting on and fastened to floor runner with sheet metal screws. Stud spacing not to exceed 24 in. (610 mm) OC.
 - C. Gypsum Board* — Gypsum board installed to a min total thickness of 5/8 or 1-1/4 in. (16 or 32 mm) on each side of wall for a 1 or 2 hr rated wall, respectively. Wall to be constructed as specified in the individual U400 or V400 Series Design in the UL Fire Resistance Directory, except that a max 3/4 in. (19 mm) gap shall be maintained between the bottom of gypsum board and top of concrete floor. The hourly fire rating of the joint system is equal to the hourly fire rating of the wall.
3. Fill, Void or Cavity Material* Sealant — Max separation between top of floor and bottom of gypsum board is 3/4 in. (19 mm). For 1 and 2 hr rated wall assemblies, min 5/8 in. or 1-1/4 in. (16 or 1-1/4 mm) thickness of fill material, respectively, installed on each side of the wall between the bottom of the gypsum board and the top of the concrete floor, flush with each surface of the wall.
HILTI CONSTRUCTION CHEMICALS, DIV OF HILTI INC — CP601S Elastomeric Firestop Sealant, CP606 Flexible Firestop Sealant, CFS-S SIL GG, FS-ONE Sealant or FS-ONE MAX Intumescent Sealant

* Indicates such products shall bear the UL or cUL Certification Mark for jurisdictions employing the UL or cUL Certification (such as Canada), respectively.



Hilti Firestop Systems

Reproduced by HILTI, Inc. Courtesy of
Underwriters Laboratories, Inc.
January 26, 2015