



Classified by
Underwriters Laboratories, Inc.
to UL 1479 and CAN/ULC-S115

System No. W-J-3167

WJ 3167

ANSI/UL1479 (ASTM E814)	CAN/ULC S115
F Ratings — 2, 3 and 4 Hr (See Items 1 and 2)	F Ratings — 2, 3 and 4 Hr (See Items 1 and 2)
T Ratings — 0, 1/2, 1-1/2 and 2 Hr (See Items 2 and 3)	FT Ratings — 1/2, 1, 1-1/2, and 2 Hr (See Items 2 and 3)
L Rating At Ambient — See Item 2	FH Ratings — 2, 3, or 4 Hr (See Items 1 and 2)
L Ratings At 400 F — See Item 2	FTH Ratings — 1/2, 1, 1-1/2, and 2 Hr (See Items 2 and 3)
	L Rating At Ambient — (See Item 2)
	L Ratings At 204 C — (See Item 2)

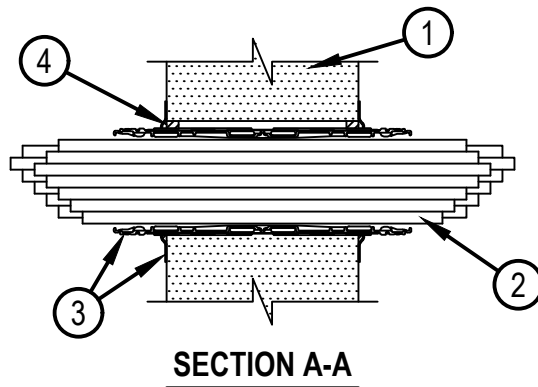
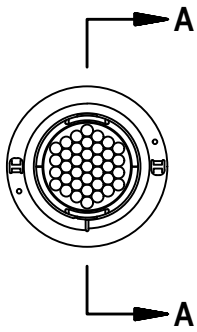

1. Wall Assembly — Min 5 in. (127 mm) thick for 2 hr wall assembly, min 5-5/8 in. (142 mm) thick for 3 hr wall assembly, min 6-1/2 in. (167 mm) thick for 4 hr wall assembly, reinforced lightweight or normal weight (100-150 pcf or 1600-2400 kg/m³) concrete. Wall may also be constructed of any UL Classified Concrete Blocks*. Opening in wall to be max 2-1/2 in. (64 mm) diam for 2" device and max 4-1/2 in. (114 mm) diam for 4" device.

See Concrete Blocks (CAZT) category in the Fire Resistance Directory for names of manufacturers.

2. Cables — Within the loading area for each firestop device, the cables may represent a 0 to 100 percent visual fill. Cables to be tightly bundled within the device and rigidly supported on both sides of wall assembly. Any combination of the following types of cables may be used:

- A. Max 100 pair No. 24 AWG (or smaller) copper conductor telecommunication cable with polyvinyl chloride (PVC) jacketing and insulation.
- B. Max 7/C No. 12 AWG copper conductor control cable with PVC or XLPE jacket and insulation.
- C. Max 4/0 AWG Type RHH ground cable.
- D. Max 4 pr No. 22 AWG Cat 5 or Cat 6 computer cables.
- E. Max RG 6/U coaxial cable with fluorinated ethylene insulation and jacketing.
- F. Fiber optic cable with polyvinyl chloride (PVC) or polyethylene (PE) jacket and insulation having a max diam of 1/2 in. (13 mm).
- G. Max 20/C No. 22 AWG shielded printer cable with PVC jacket.
- H. Through-Penetrating Product* - Two copper conductors No. 18 AWG (or smaller) Power or Non Power Limited Fire Alarm Cable with or without a jacket under a metal armor.

AFC CABLE SYSTEMS INC

I. Max 1/4 in. (6 mm) diameter S-Video Cable consisting of 2 max 24 AWG 75 ohm coax or twisted pair cable with PE insulation and PVC jacket.

J. Through Penetrating Product* — Any Cables, Metal-Clad Cable+ or Armored Cable+ currently Classified under the Through Penetrating Products category.

See Through Penetrating Product (XHLY) category in the Fire Resistance Directory for names of manufacturers.

K. Max 3/C No 12 AWG MC Cable.



Hilti Firestop Systems

Reproduced by HILTI, Inc. Courtesy of
Underwriters Laboratories, Inc.
July 02, 2018

System No. W-J-3167

WJ 3167

When cable types 2J and/or 2K are used, the hourly rating of the firestop system shall not exceed 3 hr.

When the hourly rating of the wall assembly is 2 hr, the T, FT and FTH Ratings are 1 hr except that, when Item 2H or 2I is used, the T, FT and FTH Ratings are 1/2 hr and when Items 2J or 2K are used, the T, FT and FTH Ratings are 0 hr. When the hourly rating of the wall assembly is 3 or 4 hr, the T, FT and FTH Ratings are 1-1/2 and 2 hr, respectively.

L Ratings apply only when device flanges are used. L Ratings vary depending on whether the gasketing material (see Item 3) or the sealant (Item 4) is used. See Table below for L Ratings.

Max Cable Fill	Cable Type	L Rating, CFM/Sq Ft (L/s/m ²)				L Rating, CFM (L/s)			
		Ambient		400°F (204°C)		Ambient		400°F (204°C)	
		Sealant	Gasket	Sealant	Gasket	Sealant	Gasket	Sealant	Gasket
0%	—	Less than 1 (Less than 5.1)	1.0 (5.1)	Less than 1 (Less than 5.1)	2.7 (13.7)	Less than 1 (Less than 0.5)	Less than 1 (Less than 0.5)	Less than 1 (Less than 0.5)	Less than 1 (Less than 0.5)
100%	Item 2D only	4.9 (24.9)	4.9 (24.9)	1.3 (6.6)	3.5 (17.8)	Less than 1 (Less than 0.5)	Less than 1 (Less than 0.5)	Less than 1 (Less than 0.5)	Less than 1 (Less than 0.5)
100%	Any cables (Item 2) in any combination	9.2 (46.7)	9.2 (46.7)	9.6 (48.8)	11.8 (59.9)	1.2 (0.6)	1.2 (0.6)	1.3 (0.6)	1.6 (0.8)

3. Firestop Device* — Firestop device consists of a corrugated steel tube with an inner plastic housing, intumescent material rings, twisted inner fabric smoke seal, flanges and gasketing material (not shown). Firestop device to be installed in accordance with the accompanying installation instructions. As an option, the inner fabric seal may remain open except that, to attain the L Rating, the inner fabric seal shall be twisted to completely close off the opening within device. Device slid into wall such that ends project an equal distance from the approximate centerline of the wall assembly. The annular space between the device and the periphery of the opening shall be min 0 in. (point contact). Device provided with flanges that are spun clockwise onto device threads, over gasketing material, butting tightly to both sides of wall. Device flanges are optional except for 3 and 4 hr fire rating, flanges are required. When the device flanges are not used, the T, FT and FTH Ratings for the firestop system are 0 hr. For blank opening (no cables), the T, FT and FTH Ratings for the firestop system are 2, 3 or 4 hr only when the device flanges are used. HILTI CONSTRUCTION CHEMICALS, DIV OF HILTI INC — CP 653 and CP 653 BA 2" Speed Sleeve, CP 653 and CP 653 BA 4" Speed Sleeve, CFS-SL GA L Speed Sleeves, CP 653 4" BA ILS and CFS-SL GA L ILS Speed Sleeve

The CFS-SL GA L and CFS-SL GA L ILS Speed Sleeves shall only be used in wall thickness of 8 in. (203 mm) or greater.

4. Fill, Void or Cavity Material* - Sealant — As an alternate to gasket material (see Item 3), min 1/2 in. (13 mm) thickness of fill material applied within the annulus between firestop device and wall, flush with both surfaces of wall, and an additional 1/4 in. (6 mm) bead applied around periphery of device. Sealant is required when device flanges are not used (see Item 3).

HILTI CONSTRUCTION CHEMICALS, DIV OF HILTI INC — FS-ONE MAX Intumescent Sealant, or CP 606 Sealant

* Indicates such products shall bear the UL or cUL Certification Mark for jurisdictions employing the UL or cUL Certification (such as Canada), respectively.



Hilti Firestop Systems

Reproduced by HILTI, Inc. Courtesy of
Underwriters Laboratories, Inc.
July 02, 2018