

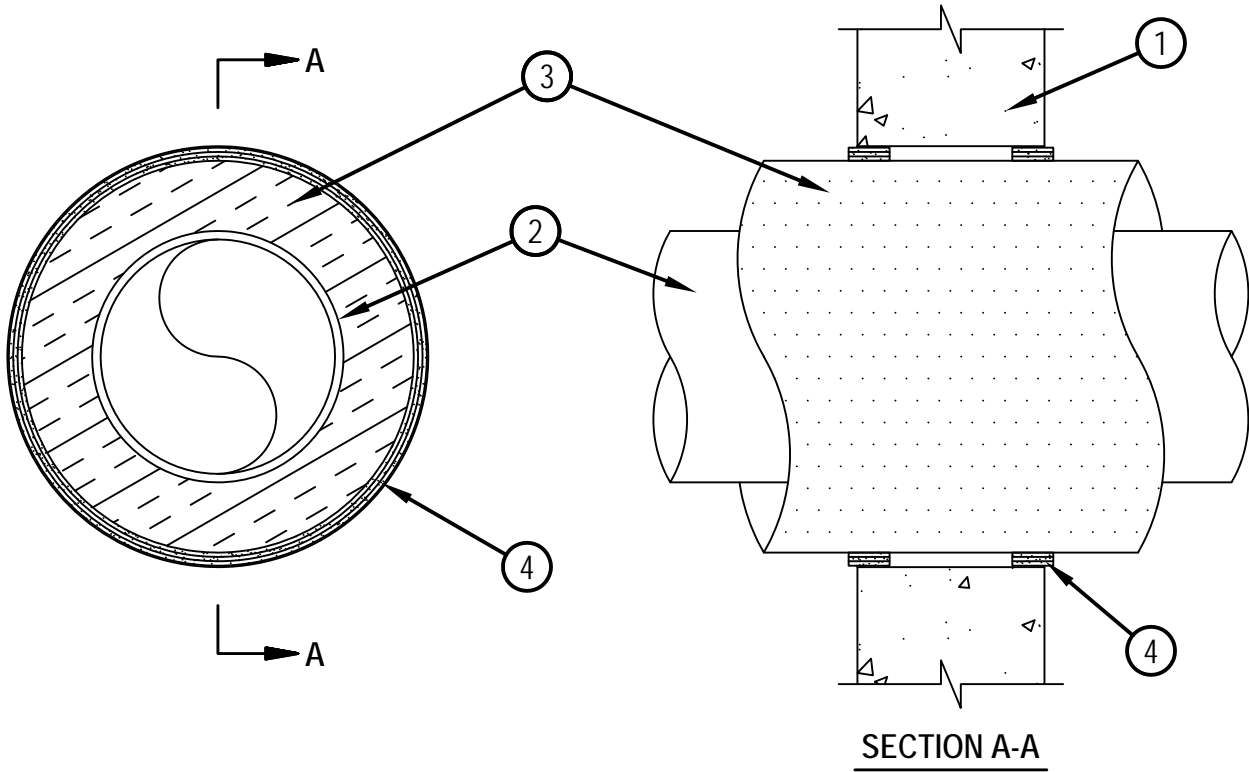

Classified by
Underwriters Laboratories, Inc.
to UL 1479 and CAN/ULC-S115

System No. W-J-5057
F Rating -- 2 Hr
T Rating -- 0 or 1 Hr (See Item 3)

WJ 5057



1. Wall Assembly -- Min 5 in. thick reinforced lightweight or normal weight (100-150 pcf) concrete. Wall may also be constructed of any UL Classified Concrete Blocks* having a minimum face shell thickness of 1-1/4 in. Max diam of opening is 18 in.

See Concrete Blocks (CAZT) category in the Fire Resistance Directory for names of manufacturers.

2. Steel Pipe -- Nom 10 in. diam (or smaller) Schedule 10 (or heavier) steel pipe. One pipe to be installed either concentrically or eccentrically within the firestop system. Pipe to be rigidly supported on both sides of floor or wall assembly.

3. Pipe Covering* -- Max 3 in. thick hollow cylindrical heavy density (min 3.5 pcf) glass fiber units jacketed on the outside with an all service jacket. Longitudinal joints sealed with metal fasteners or factory-applied self-sealing lap tape. Transverse joints secured with metal fasteners or with butt tape supplied with the product. The annular space shall be min 1/2 in. to max 3/4 in.

See Pipe and Equipment Covering -- Materials (BRGU) category in the Building Materials Directory for names of manufacturers. Any pipe covering material meeting the above specifications and bearing the UL Classification Marking with a Flame Spread Index of 25 or less and a Smoke Developed Index of 50 or less may be used. When pipe covering thickness is less than 3 in., T Rating is 0 Hr.

4. Fill, Void or Cavity Material* -- Wrap Strip -- Nom 3/16 in. thick by 1-3/4 in. wide intumescent wrap strip. The wrap strip is continuously wrapped around the outer circumference of the pipe covering three times and slid into annular space approx 1-5/8 in. such that approx 3/8 in. of the wrap strip protrudes from the wall surface. When multiple wrap strip are used to achieve the required total length, the ends are to be butted end-to-end and held in place with tape. Wrap strips are installed on each side of wall.

HILTI CONSTRUCTION CHEMICALS, DIV OF HILTI INC -- CP648-E W45/1-3/4" Wrap Strip

*Bearing the UL Classification Mark



Hilti Firestop Systems

Reproduced by HILTI, Inc. Courtesy of
Underwriters Laboratories, Inc.

April 25, 2005