



Classified by
Underwriters Laboratories, Inc.
to UL 1479 and CAN/ULC-S115

System No. W-J-8007

ANSI/UL1479 (ASTM E814)	CAN/ULC S115
F Rating — 4 Hr	F Rating — 4 Hr
T Rating — 0 Hr	FT Rating — 0 Hr
	FH Rating — 4 Hr
	FTH Rating — 0 Hr

WJ 8007

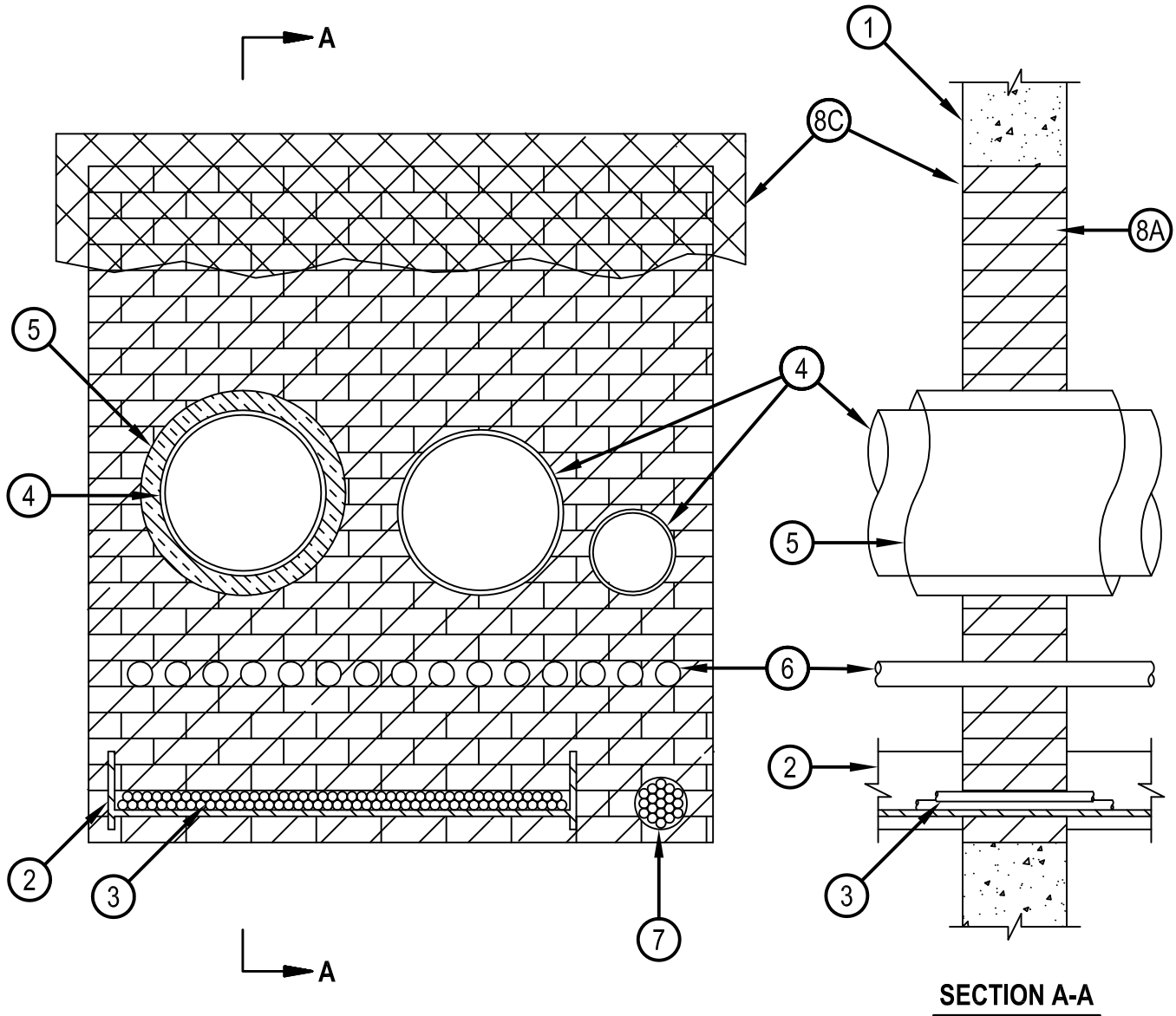

Reproduced by HILTI, Inc. Courtesy of
Underwriters Laboratories, Inc.
January 21, 2015

System No. W-J-8007

WJ 8007

1. Wall Assembly — Min 7-5/8 in. (194 mm) thick wall assembly constructed of any UL Classified Concrete Blocks*. Max area of opening is 2496 in. sq. (161 m²) with max dimension of 52 in. (1321 mm).
See Concrete Blocks (CAZT) category in the Fire Resistance Directory for names of manufacturers.
2. Cable Tray* — Max 36 in. (914 mm) wide by 6 in. (152 mm) deep open-ladder cable tray with channel-shaped side rails formed of 0.067 in. (1.7 mm) thick aluminum and with 1-1/2 in. (38 mm) wide by 3/4 in. (19 mm) deep channel-shaped rungs spaced 10 in. (254 mm) OC. One cable tray to be installed in the opening. The annular space between adjacent penetrating items shall be min 2 in. (51 mm) to max 4-1/2 in. (114 mm). The max annular space between the periphery of the opening shall be min 1 in. (25 mm) to max 3 in. (76 mm). Cable tray to be rigidly supported on both sides of wall assembly.
3. Cables — Aggregate cross-sectional area of cables in cable tray to be max 40 percent of the cross-sectional area of the cable tray based on a max 6 in. (152 mm) cable loading depth within the cable tray. Any combination of the following types and sizes of cables may be used:
 - A. 300 pair — No. 24 AWG telephone cable with polyvinyl chloride (PVC) insulation and PVC jacket.
 - B. 1/C - 500 kcmil with thermoplastic insulation and nylon jacket.
 - C. 24 fiber optic cable with polyvinyl chloride (PVC) outer and subunit jacket.
 - D. 7/C No. 12 AWG cable with polyvinyl chloride (PVC) insulation and PVC jacket.
4. Through Penetrants — One or more pipes or tubes to be installed within the opening. The total number of through-penetrants is dependent on the size of the opening and types and sizes of the penetrants. Any combination of the penetrants described below may be used provided that the following parameters relative to the annular spaces and the spacings between the pipes are maintained. The space between pipes, conduits or tubing shall be min 1-1/2 in. (38 mm) to max 4-3/4 in. (121 mm). The space between the periphery of the opening and the pipes or conduits shall be min 3 in. (76 mm) to max 4-1/4 in. (108 mm). Pipe, conduit or tubing to be rigidly supported on both sides of the wall assembly. The following types and sizes of metallic pipes, conduits or tubing may be used:
 - A. Steel Pipe — Nom 12 in. (305 mm) diam (or smaller) Schedule 10 (or heavier) steel pipe.
 - B. Iron Pipe — Nom 12 in. (305 mm) diam (or smaller) cast or ductile iron pipe.
 - C. Conduit — Nom 4 in. (102 mm) diam (or smaller) steel electric metallic tubing or 6 in. (152 mm) diam steel conduit.
 - D. Copper Tubing — Nom 6 in. (152 mm) diam (or smaller) Type L (or heavier) copper tubing.
 - E. Copper Pipe — Nom 6 in. (152 mm) diam (or smaller) Regular (or heavier) copper pipe.
5. Pipe Covering* — Nom 1-1/2 in. (38 mm) thick hollow cylindrical heavy density (3.5 pcf or 56 kg/m³) glass fiber units jacketed of the outside with an all service jacket. Longitudinal joints sealed with metal fasteners or factory-applied self-sealing lap tape. Transverse joints secured with metal fasteners or with butt tape supplied with the product.
See Pipe Equipment Covering — Materials — (BRGU) category in the Building Materials Directory for names of manufacturers. Any pipe covering material meeting the above specifications and bearing the UL Classification Marking with a Flame Spread Index of 25 or less and a Smoke Developed Index of 50 or less may be used.
- 5A. Metal Jacket — (Not Shown) — Required when pipe covering (Item 5) is used. Min 6 in. (152 mm) long jacket formed of min 0.010 in. (0.25 mm) thick steel sheet cut to wrap tightly around the pipe insulation with a min 2 in. (51 mm) lap. Jacket secured with min 1/2 in. (13 mm) wide stainless steel hose clamp located at the center of the jacket. Jacket to be installed on both surfaces of wall and recessed into the opening 1 in. (25 mm).
6. Conduit — Nom 2 in. (51 mm) diam steel electrical metallic tubing or steel conduit. A max of thirteen conduit or tubing to be installed within the opening. The space between adjacent conduits or tubing shall be 1-1/8 in. (28 mm). The space between conduits or tubing and the periphery of the opening shall be min 1-1/8 in. (28 mm) to max 2-1/2 in. (64 mm). The space between conduits or tubing and other types of penetrating items shall be min 4-1/2 in. (114 mm) to max 4-3/4 in. (121 mm). Conduit or tubing to be rigidly supported on both sides of the wall assembly.



Hilti Firestop Systems

Reproduced by HILTI, Inc. Courtesy of
Underwriters Laboratories, Inc.
January 21, 2015

Page: 2 of 3

System No. W-J-8007

WJ 8007

7. Cables — Max 4 in. (102 mm) diam tight bundle. The space between the bundle and adjacent penetrating items shall be min 2 in. (51 mm) to 6 in. (152 mm) max and between the periphery of the opening and the bundle shall be min 1-1/2 in. (38 mm) and 2-1/4 in. (57 mm) max. Cable bundle to be rigidly supported on both sides of the wall assembly. Any combination of the following types and sizes of cables may be used:
- A. 300 pair — No. 24 AWG telephone cable with polyvinyl chloride (PVC) insulation and PVC jacket.
 - B. 24 fiber optic cable with polyvinyl chloride (PVC) outer and submit jacket.
 - C. 7/C No. 12 AWG cable with polyvinyl chloride (PVC) insulation and PVC jacket.
 - D. RGU/59 coaxial cable with polyvinyl chloride (PVC) insulation and PVC jacket.
 - E. 2/C No. 10 AWG cable with ground with polyvinyl chloride (PVC) insulation and PVC jacket.
 - F. Three 1/C No. 18 AWG wire with polyvinyl chloride (PVC) insulation in a nom 3/4 in. flexible metal conduit.
8. Firestop System — The firestop system shall consist of the following:
- A. Fill, Void or Cavity Material* — Fire blocks installed with long dimension passed through the opening from surface to surface. Blocks to be firmly packed and completely fill the entire opening. Either one or a combination of the block types specified below may be used.
HILTI CONSTRUCTION CHEMICALS, DIV OF HILTI INC — FS 657 Fire Block or CFS-BL Firestop Block
 - B. Fill, Void or Cavity Material* — Fill material to be forced into interstices of cables, between cables and cable tray, between the penetrants and the Fire Blocks and in obvious openings between blocks, and between blocks and the periphery of the opening to the max extent possible on both surfaces of wall.
HILTI CONSTRUCTION CHEMICALS, DIV OF HILTI INC — FS-ONE Sealant, FS-ONE MAX Intumescent Sealant or CP 618 Putty Stick
 - C. Wire Mesh — When the annular space exceeds 4 in. (102 mm) to the periphery, a nom 2 sq. in. (12.9 cm²) wire fencing shall be used to keep the blocks in place. The wire fencing is fabricated from min No. 16 SWG (0.060 in.) galv steel wire. The wire is cut to fit the contour of the penetrating item with a min 3 in. (76 mm) lap beyond the periphery of the opening. Wire fencing secured to both surfaces of the wall assembly by means of 1/4 in. (6 mm) diam by 4-3/16 in. (106 mm) long hollow wall anchors and 1/4 in. (6 mm) by 1-1/2 in. (38 mm) diam fender washers spaced max 8 in. (203 mm) OC.

* Indicates such products shall bear the UL or cUL Certification Mark for jurisdictions employing the UL or cUL Certification (such as Canada), respectively.



Hilti Firestop Systems

Reproduced by HILTI, Inc. Courtesy of
Underwriters Laboratories, Inc.
January 21, 2015

Page: 3 of 3