



Classified by  
Underwriters Laboratories, Inc.  
to UL 1479

## System No. F-A-2270

F Rating — 3 Hr  
T Rating — 3 Hr

FA 2270

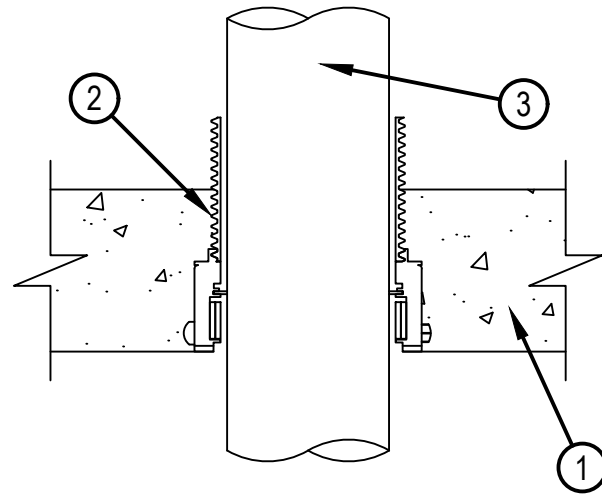
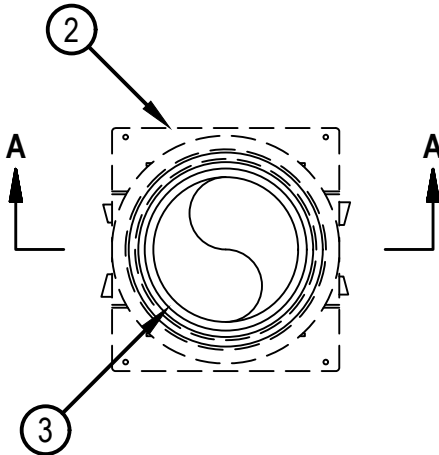

**SECTION A-A**

1. Floor Assembly — Min 4-1/2 in. (114 mm) thick reinforced lightweight or normal weight (100-150 pcf or 1600-2400 kg/m<sup>3</sup>) concrete.
2. Firestop Device\* — Cast in place firestop device permanently embedded during concrete placement or grouted in concrete assembly in accordance with accompanying installation instructions with a max 2 in. (51 mm) projection above the top surface of the concrete.  
HILTI CONSTRUCTION CHEMICALS, DIV OF HILTI INC — CP 680-P 2", CP 680-P 3", CP 680-P 4", CP 680-PX 2", CP 680-PX 3"
3. Through Penetrants — One nonmetallic pipe to be installed within the firestop system. Pipe to be rigidly supported on both sides of floor-ceiling assembly. The following types and sizes of nonmetallic pipes may be used:
  - A. Polypropylene Random (PP-R) Pipe — Nom 4 in. (125 mm) diam (or smaller) SDR 7.4 Aquatherm Green pipe for use in closed (process or supply) piping systems.

Nom Pipe Diameter	Firestop Device
2 in. (63 mm)	CP 680-P 2" CP 680-PX 2"
3 in. (90 mm)	CP 680-P 3" CP 680-PX 3"
4 in. (125 mm)	CP 680-P 4"

Note: Metric dimensions for pipes shown in parenthesis are actual metric OD's marked on pipe.

When pipe diameters other than those shown in the above table are used, pipes shall be installed in conjunction with Item 4.

4. Packing Material — (Not Shown) When pipe sizes are less than those shown in the above table, a 4 in. (102 mm) thickness of 4 pcf (64 kg/m<sup>3</sup>) mineral wool insulation shall be firmly packed to the fullest extent possible within annulus flush with top surface of device.

\* Indicates such products shall bear the UL or cUL Certification Mark for jurisdictions employing the UL or cUL Certification (such as Canada), respectively.



**Hilti Firestop Systems**

Reproduced by HILTI, Inc. Courtesy of  
Underwriters Laboratories, Inc.  
November 29, 2016