



YOUR EVERYDAY SEISMIC EXPANSION ANCHOR

Hilti Kwik Bolt VTZ



1	Product Description
2	Material Specifications
3	Technical Data
4	Installation instructions
5	Ordering Information

1 PRODUCT DESCRIPTION

The Kwik Bolt VTZ (KB-VTZ) is a torque controlled expansion anchor which is suitable for everyday seismic and cracked concrete applications. The anchor diameters range from 3/8-, 1/2-, 5/8- and 3/4-inch with two embedment depths per diameter. Applicable base materials include normal-weight concrete, structural lightweight concrete, and lightweight concrete over metal deck.

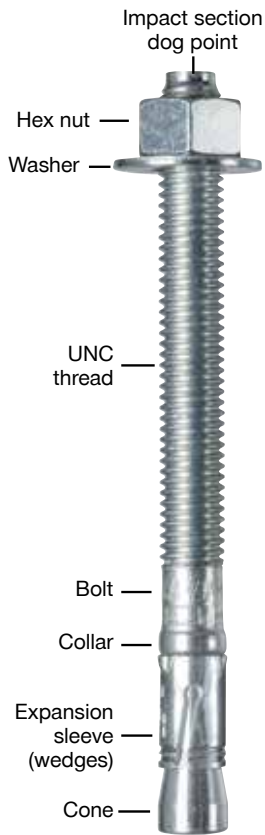

Guide specifications

Torque-controlled expansion anchors shall be Kwik Bolt VTZ (KB-VTZ) supplied by Hilti meeting the description in Federal Specification A-A 1923A, type 4. The anchor bears a length identification mark embossed into the impact section (dog point) of the anchor. The carbon steel anchor body, nut, and washer have an electroplated zinc coating conforming to ASTM B633 to a minimum thickness of 5 µm.

Product features

- Length identification marks facilitate quality control after installation.
- Through-fixture installation and multiple anchor lengths improve productivity and accommodate various base plate thicknesses.
- Mechanical expansion allows for immediate load application.
- Raised impact section (dog point) prevents thread damage during installation.
- Bolt meets ductility requirements of ACI 318-14 Section 2.3.

2 MATERIAL SPECIFICATIONS

Carbon steel with electroplated zinc

- Carbon steel anchor and expansion sleeve (wedge) components plated in accordance with ASTM B633 to a minimum thickness of 5 µm.
- Nuts conform to the requirements of ASTM A563, Grade A, Hex.
- Washers meet the requirements of ASTM F844.

Listings/Approvals

ICC-ES (International Code Council Evaluation Service, LLC)	ESR-3904
COLA (City of Los Angeles)	Research Report No. 26078
FM (Factory Mutual)	Pipe Hanger Components for Automatic Sprinkler Systems for 3/8, 1/2, and 3/4
UL LLC	Pipe Hanger Equipment for Fire Protection Services for 3/8 through 3/4

3 TECHNICAL DATA

3.1 ACI 318-14 Chapter 17 design

The technical data contained in this section are Hilti Simplified Design Tables. The load values were developed using the Strength Design parameters and variables of ESR-3904 and the equations within ACI 318-14 Chapter 17. For a detailed explanation of the Hilti Simplified Design Tables, refer to the Hilti North America Anchor Fastening Technical Guide. Data tables from ESR-3904 are not contained in this section, but can be found at www.icc-es.org or at www.us.hilti.com.



Independent code evaluation

IBC® / IRC® 2015
IBC® / IRC® 2012
IBC® / IRC® 2009
IBC® / IRC® 2006
National Building Code of Canada 2015
National Building Code of Canada 2010

Table 1 — Hilti Kwik Bolt VTZ installation specifications

Setting information	Symbol	Units	Nominal anchor diameter (in.)									
			3/8		1/2		5/8		3/4			
Anchor O.D.	d_a d_o^1	in. (mm)	3/8 (10)		1/2 (13)		5/8 (16)		3/4 (19)			
Nominal bit diameter	d_{bit}	in.	3/8		1/2		5/8		3/4			
Effective min. embedment	h_{ef}	in. (mm)	1-1/2 (38)	2 (51)	2 (51)	3-1/4 (83)	2-3/4 (70)	4 (102)	3-1/8 (79)	4-3/4 (121)		
Minimum nominal embedment	h_{nom}	in. (mm)	1-13/16 (46)	2-5/16 (59)	2-1/2 (64)	3-3/4 (95)	3-5/16 (84)	4-9/16 (116)	3-3/4 (95)	5-3/8 (137)		
Min. hole depth	h_o	in. (mm)	2 (51)	2-1/2 (64)	2-3/4 (70)	4 (102)	3-5/8 (92)	4-7/8 (124)	4-1/16 (103)	5-11/16 (144)		
Max. thickness of fixture ²	h_o	in. (mm)	2-13/16 (71)	2-5/16 (59)	2-1/2 (64)	1-1/4 (32)	2-1/16 (52)	13/16 (21)	2-1/2 (64)	7/8 (22)		
Installation torque	T_{inst}	ft-lb (Nm)	20 (27)		40 (54)		60 (81)		110 (149)			
Fixture hole diameter	d_h	in. (mm)	7/16 (11.1)		9/16 (14.3)		11/16 (17.5)		13/16 (20.6)			
Available anchor lengths	l_{anch}	in. (mm)	3 (76)	3-3/4 (95)	5 (127)	3-3/4 (95)	4-1/2 (114)	5-1/2 (140)	4-3/4 (121)	6 (152)	5-1/2 (140)	7 (178)

1 d_o is used for the 2006/2003 IBC

2 This maximum thickness applies when the longest anchor length is used. For shorter anchor lengths, the maximum fixture thickness is equal to the anchor length less the nominal embedment less one anchor diameter.

Table 2 — Steel strength for Hilti Kwik Bolt VTZ anchors^{1,2}

Nominal anchor diameter in.	Effective anchor embedment in. (mm)	Tensile ³ ΦN_{sa} lb (kN)	Shear ⁴ ΦV_{sa} lb (kN)	Seismic shear ⁵ ΦV_{sa} lb (kN)
3/8	1-1/2 (38)	4,500 (20.0)	1,255 (5.6)	1,255 (5.6)
	2 (51)	4,500 (20.0)	1,775 (7.9)	1,610 (7.2)
1/2	2 (51)	8,080 (35.9)	3,005 (13.4)	3,005 (13.4)
5/8	2-3/4 (70)	12,400 (55.2)	5,760 (25.6)	3,925 (17.5)
3/4	3-1/8 (83)	16,915 (75.2)	6,715 (29.9)	5,855 (26.0)
	4-3/4 (121)	16,915 (75.2)	6,905 (30.7)	6,700 (29.8)

1 See the Hilti North America Anchor Fastening Technical Guide to convert design strength value to ASD value.

2 Hilti Kwik Bolt VTZ anchors are permitted to be considered ductile steel elements as defined by ACI 318-14 Section 2.3.

3 Tensile $N_{sar} = A_{se,N} \Phi_s f_{uts} R$ as noted in CSA A23.3-14, Annex D.

4 Shear determined by static shear tests with $V_{sar} < A_{se,V} \Phi_s 0.6 f_{uts} R$ as noted in CSA A23.3-14, Annex D.

5 Seismic shear values determined by seismic shear tests with $V_{sar,eq} < A_{se,V} \Phi_s 0.6 f_{uts} R$ as noted in CSA A23.3-14, Annex D. See the Hilti North America Anchor Fastening Technical Guide for additional information on seismic applications.

Figure 1 — Hilti Kwik Bolt VTZ specifications

Table 3 — Hilti Kwik Bolt VTZ design strength with concrete / pullout failure in uncracked concrete^{1,2,3,4,5}

Nominal anchor diameter in.	Effective embed. in. (mm)	Nominal embed. in. (mm)	Tension - ϕN_n				Shear - ϕV_n			
			$f'_c = 2,500$ psi lb (kN)	$f'_c = 3,000$ psi lb (kN)	$f'_c = 4,000$ psi lb (kN)	$f'_c = 6,000$ psi lb (kN)	$f'_c = 2,500$ psi lb (kN)	$f'_c = 3,000$ psi lb (kN)	$f'_c = 4,000$ psi lb (kN)	$f'_c = 6,000$ psi lb (kN)
3/8	1-1/2 (38)	1-13/16 (46)	1,380 (6.1)	1,510 (6.7)	1,745 (7.8)	2,135 (9.5)	1,545 (6.9)	1,690 (7.5)	1,950 (8.7)	2,390 (10.6)
	2 (51)	2-5/16 (59)	1,620 (7.2)	1,775 (7.9)	2,045 (9.1)	2,505 (11.1)	2,375 (10.6)	2,605 (11.6)	3,005 (13.4)	3,680 (16.4)
1/2	2 (51)	2-1/2 (64)	1,985 (8.8)	2,170 (9.7)	2,510 (11.2)	3,070 (13.7)	2,375 (10.6)	2,605 (11.6)	3,005 (13.4)	3,680 (16.4)
	3-1/4 (83)	3-3/4 (95)	3,550 (15.8)	3,890 (17.3)	4,490 (20.0)	5,500 (24.5)	9,845 (43.8)	10,785 (48.0)	12,450 (55.4)	15,250 (67.8)
5/8	2-3/4 (70)	3-5/16 (84)	3,140 (14.0)	3,440 (15.3)	3,970 (17.7)	4,865 (21.6)	7,660 (34.1)	8,395 (37.3)	9,690 (43.1)	11,870 (52.8)
	4 (102)	4-9/16 (116)	4,100 (18.2)	4,495 (20.0)	5,190 (23.1)	6,355 (28.3)	13,440 (59.8)	14,725 (65.5)	17,000 (75.6)	20,820 (92.6)
3/4	3-1/8 (83)	3-3/4 (95)	4,310 (19.2)	4,720 (21.0)	5,450 (24.2)	6,675 (29.7)	9,280 (41.3)	10,165 (45.2)	11,740 (52.2)	14,380 (64.0)
	4-3/4 (121)	5-3/8 (137)	6,870 (30.6)	7,525 (33.5)	8,690 (38.7)	10,645 (47.4)	17,390 (77.4)	19,050 (84.7)	22,000 (97.9)	26,945 (119.9)

Table 4 — Hilti Kwik Bolt VTZ design strength with concrete / pullout failure in cracked concrete^{1,2,3,4,5}

Nominal anchor diameter in.	Effective embed. in. (mm)	Nominal embed. in. (mm)	Tension - ϕN_n				Shear - ϕV_n			
			$f'_c = 2,500$ psi lb (kN)	$f'_c = 3,000$ psi lb (kN)	$f'_c = 4,000$ psi lb (kN)	$f'_c = 6,000$ psi lb (kN)	$f'_c = 2,500$ psi lb (kN)	$f'_c = 3,000$ psi lb (kN)	$f'_c = 4,000$ psi lb (kN)	$f'_c = 6,000$ psi lb (kN)
3/8	1-1/2 (38)	1-13/16 (46)	775 (3.4)	845 (3.8)	980 (4.4)	1,200 (5.3)	1,095 (4.9)	1,195 (5.3)	1,385 (6.2)	1,695 (7.5)
	2 (51)	2-5/16 (59)	1,325 (5.9)	1,455 (6.5)	1,675 (7.5)	2,055 (9.1)	1,685 (7.5)	1,845 (8.2)	2,130 (9.5)	2,605 (11.6)
1/2	2 (51)	2-1/2 (64)	1,565 (7.0)	1,710 (7.6)	1,975 (8.8)	2,420 (10.8)	1,685 (7.5)	1,845 (8.2)	2,130 (9.5)	2,605 (11.6)
	3-1/4 (83)	3-3/4 (95)	2,120 (9.4)	2,320 (10.3)	2,680 (11.9)	3,285 (14.6)	6,970 (31.0)	7,640 (34.0)	8,820 (39.2)	10,800 (48.0)
5/8	2-3/4 (70)	3-5/16 (84)	2,520 (11.2)	2,760 (12.3)	3,185 (14.2)	3,905 (17.4)	5,425 (24.1)	5,945 (26.4)	6,865 (30.5)	8,405 (37.4)
	4 (102)	4-9/16 (116)	3,185 (14.2)	3,490 (15.5)	4,030 (17.9)	4,935 (22.0)	9,520 (42.3)	10,430 (46.4)	12,040 (53.6)	14,750 (65.6)
3/4	3-1/8 (83)	3-3/4 (95)	3,770 (16.8)	4,130 (18.4)	4,770 (21.2)	5,840 (26.0)	8,120 (36.1)	8,895 (39.6)	10,270 (45.7)	12,580 (56.0)
	4-3/4 (121)	5-3/8 (137)	5,720 (25.4)	6,265 (27.9)	7,235 (32.2)	8,860 (39.4)	12,320 (54.8)	13,495 (60.0)	15,585 (69.3)	19,085 (84.9)

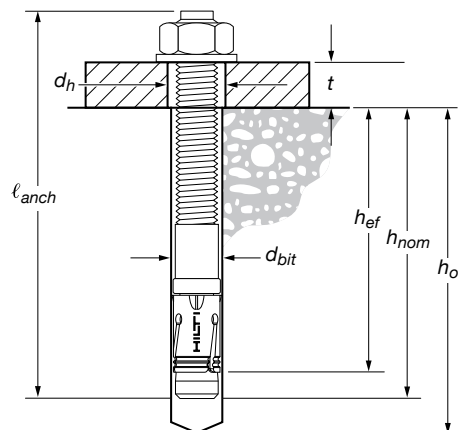
- 1 See the Hilti North America Anchor Fastening Technical Guide to convert design strength value to ASD value.
- 2 Linear interpolation between embedment depths and concrete compressive strengths is not permitted.
- 3 Apply spacing, edge distance, and concrete thickness factors in tables 6 through 13 as necessary. Compare to the steel values in table 2; the lesser of the values is to be used for the design.
- 4 Tabular values are for normal weight concrete only. For lightweight concrete multiply design strength by λ_a as follows: for sand-lightweight, $\lambda_a = 0.68$; for all-lightweight, $\lambda_a = 0.60$
- 5 Tabular values are for static loads only. Seismic design is not permitted for uncracked concrete. For seismic tension loads, multiply cracked concrete tabular values in tension only by $\alpha_{N,seis} = 0.75$. No seismic reduction needed for shear values in this table. See the Hilti North America Anchor Fastening Technical Guide for additional information on seismic applications.

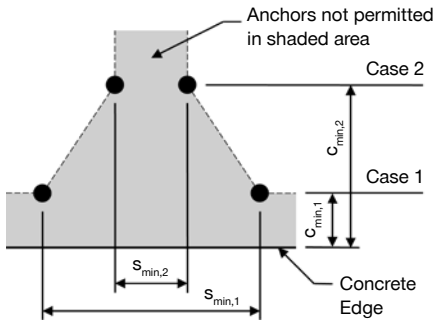
Figure 2 – Permissible combinations of edge distance and spacing

For a specific edge distance, the permitted spacing is calculated as follows:

$$s \geq s_{min,2} + \frac{(s_{min,1} - s_{min,2})}{(c_{min,1} - c_{min,2})} (c - c_{min,2})$$

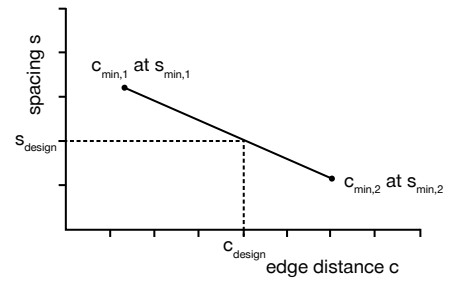
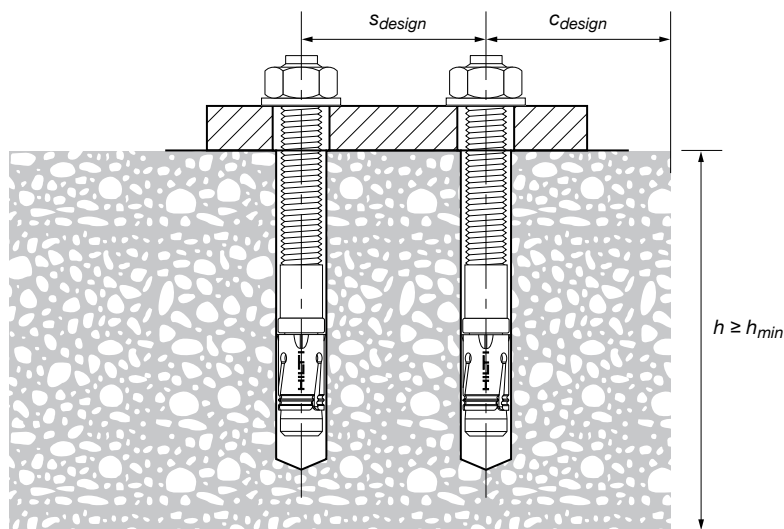
Figure 3 – Schematic of edge distance, spacing, and member thickness used in design

Table 5 – Hilti Kwik Bolt VTZ installation parameters¹

Design information	Symbol	Units	Nominal anchor diameter d_o							
			3/8		1/2		5/8		3/4	
Effective min. embedment ²	h_{ef}	in. (mm)	1-1/2 (38)	2 (51)	2 (51)	3-1/4 (83)	2-3/4 (70)	4 (102)	3-1/8 (79)	4-3/4 (121)
Min. member thickness ³	h_{min}	in. (mm)	3-1/4 (83)	4 (102)	4 (102)	6 (152)	6 (152)	7 (178)	6 (152)	10 (254)
Critical edge distance	c_{ac}	in. (mm)	6 (152)	8 (203)	8 (203)	5 (127)	6 (152)	9 (229)	11 (279)	16 (406)
Case 1	$c_{min,1}$	in. (mm)	2-3/4 (70)	2-1/4 (57)	3-1/4 (83)	2-3/4 (70)	5-1/2 (140)	4-1/4 (108)	5 (127)	6 (152)
	for $s_{min,1} \geq$	in. (mm)	9 (229)	3-3/4 (95)	10 (254)	6 (152)	11 (279)	4-1/4 (108)	6 (152)	6-1/2 (165)
Case 2	$s_{min,2}$	in. (mm)	3-1/2 (89)	3-1/4 (83)	4-1/2 (114)	4 (102)	6-1/2 (165)	4-1/4 (108)	5 (127)	6 (152)
	for $c_{min,2} \geq$	in. (mm)	6 (152)	5-1/4 (133)	6 (152)	5 (127)	6-1/2 (165)	4-1/4 (108)	6 (152)	6-1/2 (165)

¹ Linear interpolation is permitted to establish an edge distance and spacing combination between Case 1 and Case 2. Linear interpolation for a specific edge distance c , where $c_{min,1} < c < c_{min,2}$, will determine the permissible spacings.

Table 6 – Load adjustment factors for 3/8-in. diameter Hilti Kwik Bolt VTZ in uncracked concrete^{1,2}

3/8-in. KB-VTZ uncracked concrete		Spacing factor in tension f_{AN}		Edge distance factor in tension f_{RN}		Spacing factor in shear ³ f_{AV}		Edge distance in shear				Conc. thickness factor in shear ⁴ f_{HV}	
								⊥ Toward edge f_{RV}		∥ To and away from edge f_{RV}			
Effective embed. h_{ef}	in. (mm)	1-1/2 (38)	2 (51)	1-1/2 (38)	2 (51)	1-1/2 (38)	2 (51)	1-1/2 (38)	2 (51)	1-1/2 (38)	2 (51)	1-1/2 (38)	2 (51)
Nominal embed. h_{nom}	in. (mm)	1-13/16 (46)	2-5/16 (59)	1-13/16 (46)	2-5/16 (59)	1-13/16 (46)	2-5/16 (59)	1-13/16 (46)	2-5/16 (59)	1-13/16 (46)	2-5/16 (59)	1-13/16 (46)	2-5/16 (59)
Spacing (s) / edge distance (c_e) / concrete thickness (h) - in. (mm)	2-1/4 (57)	n/a	n/a	n/a	0.30	n/a	n/a	n/a	0.15	n/a	0.30	n/a	n/a
	2-3/4 (70)	n/a	n/a	0.46	0.35	n/a	n/a	0.31	0.20	0.46	0.35	n/a	n/a
	3 (76)	n/a	n/a	0.50	0.38	n/a	n/a	0.35	0.23	0.50	0.38	n/a	n/a
	3-1/4 (83)	n/a	0.77	0.54	0.41	n/a	0.57	0.40	0.26	0.54	0.41	0.60	n/a
	3-1/2 (89)	0.89	0.79	0.58	0.44	0.60	0.57	0.45	0.29	0.58	0.44	0.62	n/a
	3-3/4 (95)	0.92	0.81	0.63	0.47	0.60	0.58	0.49	0.32	0.63	0.47	0.65	n/a
	4 (102)	0.94	0.83	0.67	0.50	0.61	0.58	0.54	0.35	0.67	0.50	0.67	0.58
	4-1/2 (114)	1.00	0.88	0.75	0.56	0.63	0.59	0.65	0.42	0.75	0.56	0.71	0.61
	5 (127)	1.00	0.92	0.83	0.63	0.64	0.60	0.76	0.49	0.83	0.63	0.75	0.65
	5-1/4 (133)	1.00	0.94	0.88	0.66	0.65	0.61	0.82	0.53	0.88	0.66	0.76	0.66
	5-1/2 (140)	1.00	0.96	0.92	0.69	0.65	0.61	0.88	0.57	0.92	0.69	0.78	0.68
	6 (152)	1.00	1.00	1.00	0.75	0.67	0.63	1.00	0.65	1.00	0.75	0.82	0.71
	8 (203)	1.00			1.00	0.72	0.67		1.00		1.00	0.94	0.82
	12 (305)	1.00				0.83	0.75					1.00	1.00
18 (457)					1.00	0.88							
24 (610)						1.00							

Table 7 – Load adjustment factors for 3/8-in. diameter Hilti Kwik Bolt VTZ in cracked concrete^{1,2}

3/8-in. KB-VTZ cracked concrete		Spacing factor in tension f_{AN}		Edge distance factor in tension f_{RN}		Spacing factor in shear ³ f_{AV}		Edge distance in shear				Conc. thickness factor in shear ⁴ f_{HV}	
								⊥ Toward edge f_{RV}		∥ To and away from edge f_{RV}			
Effective embed. h_{ef}	in. (mm)	1-1/2 (38)	2 (51)	1-1/2 (38)	2 (51)	1-1/2 (38)	2 (51)	1-1/2 (38)	2 (51)	1-1/2 (38)	2 (51)	1-1/2 (38)	2 (51)
Nominal embed. h_{nom}	in. (mm)	1-13/16 (46)	2-5/16 (59)	1-13/16 (46)	2-5/16 (59)	1-13/16 (46)	2-5/16 (59)	1-13/16 (46)	2-5/16 (59)	1-13/16 (46)	2-5/16 (59)	1-13/16 (46)	2-5/16 (59)
Spacing (s) / edge distance (c_e) / concrete thickness (h) - in. (mm)	2-1/4 (57)	n/a	n/a	n/a	0.81	n/a	n/a	n/a	0.42	n/a	0.81	n/a	n/a
	2-3/4 (70)	n/a	n/a	1.00	0.93	n/a	n/a	0.83	0.57	1.00	0.93	n/a	n/a
	3 (76)	n/a	n/a	1.00	1.00	n/a	n/a	0.94	0.65	1.00	1.00	n/a	n/a
	3-1/4 (83)	n/a	0.77	1.00	1.00	n/a	0.64	1.00	0.73	1.00	1.00	0.83	n/a
	3-1/2 (89)	0.89	0.79	1.00	1.00	0.69	0.65	1.00	0.82	1.00	1.00	0.86	n/a
	3-3/4 (95)	0.92	0.81	1.00	1.00	0.70	0.66	1.00	0.90	1.00	1.00	0.89	n/a
	4 (102)	0.94	0.83	1.00	1.00	0.71	0.67	1.00	1.00	1.00	1.00	0.92	0.82
	4-1/2 (114)	1.00	0.88	1.00	1.00	0.74	0.69	1.00	1.00	1.00	1.00	0.98	0.87
	5 (127)	1.00	0.92	1.00	1.00	0.77	0.71	1.00	1.00	1.00	1.00	1.00	0.91
	5-1/4 (133)	1.00	0.94	1.00	1.00	0.78	0.72	1.00	1.00	1.00	1.00		0.93
	5-1/2 (140)	1.00	0.96	1.00		0.79	0.73	1.00		1.00			0.96
	6 (152)	1.00	1.00	1.00		0.82	0.75	1.00		1.00			1.00
	8 (203)	1.00				0.93	0.83						
	12 (305)	1.00				1.00	1.00						

1 Linear interpolation not permitted.

2 These values are applicable for groups of up to four anchors with all factors applied in both directions. When combining multiple load adjustment factors (e.g., for a 4 anchor pattern in a corner with thin concrete member) the design can become very conservative. To optimize the design, and for groups of greater than four anchors use Hilti PROFIS Anchor Design software or perform anchor calculation using design equations from ACI 318-14 Chapter 17.

3 Spacing factor reduction in shear, f_{AV} , assumes an influence of a nearby edge. If no edge exists, $f_{AV} = f_{AN}$.

4 Concrete thickness reduction factor in shear, f_{HV} , assumes an influence of a nearby edge. If no edge exists, $f_{HV} = 1.0$.

If a reduction factor value is in a shaded cell, this indicates that this specific edge distance may not be permitted with a certain spacing (or vice versa). Check with table 5 and figure 2 to calculate permissible edge distance, spacing, and concrete thickness combinations.

Table 8 — Load adjustment factors for 1/2-in. diameter Hilti Kwik Bolt VTZ in uncracked concrete^{1,2}

1/2-in. KB-VTZ uncracked concrete		Spacing factor in tension f_{AN}		Edge distance factor in tension f_{RN}		Spacing factor in shear ³ f_{AV}		Edge distance in shear				Conc. thickness factor in shear ⁴ f_{HV}	
								⊥ toward edge f_{RV}		to and away from edge f_{RV}			
Effective embed. h_{ef}	in. (mm)	2 (51)	3-1/4 (83)	2 (51)	3-1/4 (83)	2 (51)	3-1/4 (83)	2 (51)	3-1/4 (83)	2 (51)	3-1/4 (83)	2 (51)	3-1/4 (83)
Nominal embed. h_{nom}	in. (mm)	2-1/2 (64)	3-3/4 (95)	2-1/2 (64)	3-3/4 (95)	2-1/2 (64)	3-3/4 (95)	2-1/2 (64)	3-3/4 (95)	2-1/2 (64)	3-3/4 (95)	2-1/2 (64)	3-3/4 (95)
Spacing (s) / edge distance (c_1) / concrete thickness (h) - in. (mm)	2-3/4 (70)	n/a	n/a	n/a	0.66	n/a	n/a	n/a	0.16	n/a	0.33	n/a	n/a
	3 (76)	n/a	n/a	n/a	0.70	n/a	n/a	n/a	0.19	n/a	0.37	n/a	n/a
	3-1/4 (83)	n/a	n/a	0.41	0.73	n/a	n/a	0.26	0.21	0.41	0.42	n/a	n/a
	3-1/2 (89)	n/a	n/a	0.44	0.77	n/a	n/a	0.29	0.23	0.44	0.47	n/a	n/a
	4 (102)	n/a	0.71	0.50	0.84	n/a	0.57	0.35	0.29	0.50	0.57	0.58	n/a
	4-1/2 (114)	0.88	0.73	0.56	0.92	0.59	0.58	0.42	0.34	0.56	0.68	0.61	n/a
	5 (127)	0.92	0.76	0.63	1.00	0.60	0.59	0.49	0.40	0.63	0.80	0.65	n/a
	5-1/2 (140)	0.96	0.78	0.69		0.61	0.60	0.57	0.46	0.69	0.92	0.68	n/a
	6 (152)	1.00	0.81	0.75		0.63	0.61	0.65	0.53	0.75	1.00	0.71	0.66
	8 (203)	1.00	0.91	1.00		0.67	0.64	1.00	0.81	1.00		0.82	0.76
	10 (254)	1.00	1.00			0.71	0.68	1.00	1.00			0.91	0.85
	12 (305)					0.75	0.72	1.00				1.00	0.93
	14 (356)					0.79	0.75	1.00					1.00
	16 (406)					0.83	0.79	1.00					
	20 (508)					0.92	0.86	1.00					
24 (610)					1.00	0.93	1.00						
26 (660)						0.97	1.00						
≥ 28 (711)						1.00	1.00						

Table 9 — Load adjustment factors for 1/2-in. diameter Hilti Kwik Bolt VTZ in cracked concrete^{1,2}

1/2-in. KB-VTZ cracked concrete		Spacing factor in tension f_{AN}		Edge distance factor in tension f_{RN}		Spacing factor in shear ³ f_{AV}		Edge distance in shear				Conc. thickness factor in shear ⁴ f_{HV}	
								⊥ toward edge f_{RV}		to and away from edge f_{RV}			
Effective embed. h_{ef}	in. (mm)	2 (51)	3-1/4 (83)	2 (51)	3-1/4 (83)	2 (51)	3-1/4 (83)	2 (51)	3-1/4 (83)	2 (51)	3-1/4 (83)	2 (51)	3-1/4 (83)
Nominal embed. h_{nom}	in. (mm)	2-1/2 (64)	3-3/4 (95)	2-1/2 (64)	3-3/4 (95)	2-1/2 (64)	3-3/4 (95)	2-1/2 (64)	3-3/4 (95)	2-1/2 (64)	3-3/4 (95)	2-1/2 (64)	3-3/4 (95)
Spacing (s) / edge distance (c_1) / concrete thickness (h) - in. (mm)	2-3/4 (70)	n/a	n/a	n/a	0.68	n/a	n/a	n/a	0.16	n/a	0.33	n/a	n/a
	3 (76)	n/a	n/a	n/a	0.71	n/a	n/a	n/a	0.19	n/a	0.38	n/a	n/a
	3-1/4 (83)	n/a	n/a	1.00	0.75	n/a	n/a	0.80	0.21	1.00	0.42	n/a	n/a
	3-1/2 (89)	n/a	n/a	1.00	0.79	n/a	n/a	0.89	0.24	1.00	0.47	n/a	n/a
	4 (102)	n/a	0.71	1.00	0.86	n/a	0.57	1.00	0.29	1.00	0.58	0.84	n/a
	4-1/2 (114)	0.88	0.73	1.00	0.94	0.70	0.58	1.00	0.34	1.00	0.69	0.89	n/a
	5 (127)	0.92	0.76	1.00	1.00	0.72	0.59	1.00	0.40	1.00	0.81	0.94	n/a
	5-1/2 (140)	0.96	0.78	1.00		0.74	0.60	1.00	0.47	1.00	0.93	0.98	n/a
	6 (152)	1.00	0.81	1.00		0.76	0.61	1.00	0.53	1.00	1.00	1.00	0.66
	7 (178)	1.00	0.86			0.81	0.63		0.67				0.71
	8 (203)	1.00	0.91			0.85	0.65		0.82				0.76
	9 (229)	1.00	0.96			0.90	0.66		0.98				0.81
	10 (254)	1.00	1.00			0.94	0.68		1.00				0.85
	12 (305)					1.00	0.72						0.94
	14 (356)						0.76						1.00
16 (406)						0.79							
20 (508)						0.86							
24 (610)						0.94							
26 (660)						0.97							
≥ 28 (711)						1.00							

1 Linear interpolation not permitted.

2 These values are applicable for groups of up to four anchors with all factors applied in both directions. When combining multiple load adjustment factors (e.g., for a 4 anchor pattern in a corner with thin concrete member) the design can become very conservative. To optimize the design, and for groups of greater than four anchors use Hilti PROFIS Anchor Design software or perform anchor calculation using design equations from ACI 318-14 Chapter 17.

3 Spacing factor reduction in shear, f_{AV} , assumes an influence of a nearby edge. If no edge exists, $f_{AV} = f_{AN}$.

4 Concrete thickness reduction factor in shear, f_{HV} , assumes an influence of a nearby edge. If no edge exists, $f_{HV} = 1.0$.

☐ If a reduction factor value is in a shaded cell, this indicates that this specific edge distance may not be permitted with a certain spacing (or vice versa). Check with table 5 and figure 2 to calculate permissible edge distance, spacing, and concrete thickness combinations.

Table 10 – Load adjustment factors for 5/8-in. diameter Hilti Kwik Bolt VTZ in uncracked concrete^{1,2}

5/8-in. KB-VTZ uncracked concrete		Spacing factor in tension f_{AN}		Edge distance factor in tension f_{RN}		Spacing factor in shear ³ f_{AV}		Edge distance in shear				Conc. thickness factor in shear ⁴ f_{HV}	
								⊥ toward edge f_{RV}		to and away from edge f_{RV}			
Effective embed. h_{ef}	in. (mm)	2-3/4 (70)	4 (102)	2-3/4 (70)	4 (102)	2-3/4 (70)	4 (102)	2-3/4 (70)	4 (102)	2-3/4 (70)	4 (102)	2-3/4 (70)	4 (102)
Nominal embed. h_{nom}	in. (mm)	3-5/16 (84)	4-9/16 (116)	3-5/16 (84)	4-9/16 (116)	3-5/16 (84)	4-9/16 (116)	3-5/16 (84)	4-9/16 (116)	3-5/16 (84)	4-9/16 (116)	3-5/16 (84)	4-9/16 (116)
Spacing (s) / edge distance (c_e) / concrete thickness (h) - in. (mm)	4-1/4 (108)	n/a	0.68	n/a	0.52	n/a	0.57	n/a	0.26	n/a	0.51	n/a	n/a
	4-1/2 (114)	n/a	0.69	n/a	0.54	n/a	0.57	n/a	0.28	n/a	0.54	n/a	n/a
	5 (127)	n/a	0.71	n/a	0.58	n/a	0.58	n/a	0.33	n/a	0.58	n/a	n/a
	5-1/2 (140)	n/a	0.73	0.92	0.62	n/a	0.59	0.61	0.38	0.92	0.62	n/a	n/a
	6 (152)	n/a	0.75	1.00	0.67	n/a	0.59	0.70	0.43	1.00	0.67	0.72	n/a
	6-1/2 (165)	0.89	0.77	1.00	0.72	0.64	0.60	0.79	0.48	1.00	0.72	0.75	n/a
	7 (178)	0.92	0.79		0.78	0.65	0.61	0.88	0.54		0.78	0.78	0.67
	8 (203)	0.98	0.83		0.89	0.68	0.63	1.00	0.66		0.89	0.84	0.71
	9 (229)	1.00	0.88		1.00	0.70	0.64		0.79		1.00	0.89	0.75
	10 (254)	1.00	0.92			0.72	0.66		0.92			0.94	0.80
	12 (305)	1.00	1.00			0.76	0.69		1.00			1.00	0.87
	14 (356)					0.81	0.72						0.94
	16 (406)					0.85	0.75						1.00
	20 (508)					0.94	0.82						
	24 (610)					1.00	0.88						
28 (711)						0.94							
≥ 32 (813)						1.00							

Table 11 – Load adjustment factors for 5/8-in. diameter Hilti Kwik Bolt VTZ in cracked concrete^{1,2}

5/8-in. KB-VTZ cracked concrete		Spacing factor in tension f_{AN}		Edge distance factor in tension f_{RN}		Spacing factor in shear ³ f_{AV}		Edge distance in shear				Conc. thickness factor in shear ⁴ f_{HV}	
								⊥ toward edge f_{RV}		to and away from edge f_{RV}			
Effective embed. h_{ef}	in. (mm)	2-3/4 (70)	4 (102)	2-3/4 (70)	4 (102)	2-3/4 (70)	4 (102)	2-3/4 (70)	4 (102)	2-3/4 (70)	4 (102)	2-3/4 (70)	4 (102)
Nominal embed. h_{nom}	in. (mm)	3-5/16 (84)	4-9/16 (116)	3-5/16 (84)	4-9/16 (116)	3-5/16 (84)	4-9/16 (116)	3-5/16 (84)	4-9/16 (116)	3-5/16 (84)	4-9/16 (116)	3-5/16 (84)	4-9/16 (116)
Spacing (s) / edge distance (c_e) / concrete thickness (h) - in. (mm)	4-1/4 (108)	n/a	0.68	n/a	0.78	n/a	0.57	n/a	0.26	n/a	0.52	n/a	n/a
	4-1/2 (114)	n/a	0.69	n/a	0.81	n/a	0.57	n/a	0.28	n/a	0.56	n/a	n/a
	5 (127)	n/a	0.71	n/a	0.87	n/a	0.58	n/a	0.33	n/a	0.66	n/a	n/a
	5-1/2 (140)	n/a	0.73	1.00	0.93	n/a	0.59	0.62	0.38	1.00	0.76	n/a	n/a
	6 (152)	n/a	0.75	1.00	1.00	n/a	0.60	0.71	0.43	1.00	0.87	0.73	n/a
	6-1/2 (165)	0.89	0.77	1.00		0.64	0.60	0.80	0.49	1.00	0.98	0.76	n/a
	7 (178)	0.92	0.79			0.65	0.61	0.89	0.55		1.00	0.79	0.67
	8 (203)	0.98	0.83			0.68	0.63	1.00	0.67			0.84	0.71
	9 (229)	1.00	0.88			0.70	0.64		0.80			0.89	0.76
	10 (254)	1.00	0.92			0.72	0.66		0.93			0.94	0.80
	12 (305)	1.00	1.00			0.76	0.69		1.00			1.00	0.87
	14 (356)					0.81	0.72						0.94
	16 (406)					0.85	0.75						1.00
	20 (508)					0.94	0.82						
	24 (610)					1.00	0.88						
28 (711)						0.95							
≥ 32 (813)						1.00							

1 Linear interpolation not permitted.

2 These values are applicable for groups of up to four anchors with all factors applied in both directions. When combining multiple load adjustment factors (e.g., for a 4 anchor pattern in a corner with thin concrete member) the design can become very conservative. To optimize the design, and for groups of greater than four anchors use Hilti PROFIS Anchor Design software or perform anchor calculation using design equations from ACI 318-14 Chapter 17.

3 Spacing factor reduction in shear, f_{AV} , assumes an influence of a nearby edge. If no edge exists, $f_{AV} = f_{AN}$.

4 Concrete thickness reduction factor in shear, f_{HV} , assumes an influence of a nearby edge. If no edge exists, $f_{HV} = 1.0$.

□ If a reduction factor value is in a shaded cell, this indicates that this specific edge distance may not be permitted with a certain spacing (or vice versa). Check with table 5 and figure 2 to calculate permissible edge distance, spacing, and concrete thickness combinations.

Table 12 – Load adjustment factors for 3/4-in. diameter Hilti Kwik Bolt VTZ in uncracked concrete^{1,2}

3/4-in. KB-VTZ uncracked concrete		Spacing factor in tension f_{AN}		Edge distance factor in tension f_{RN}		Spacing factor in shear ³ f_{AV}		Edge distance in shear				Conc. thickness factor in shear ⁴ f_{HV}	
								⊥ toward edge f_{RV}		to and away from edge f_{RV}			
Effective embed. h_{ef}	in. (mm)	3-1/4 (83)	4-3/4 (121)	3-1/4 (83)	4-3/4 (121)	3-1/4 (83)	4-3/4 (121)	3-1/4 (83)	4-3/4 (121)	3-1/4 (83)	4-3/4 (121)	3-1/4 (83)	4-3/4 (121)
Nominal embed. h_{nom}	in. (mm)	3-3/4 (95)	5-3/8 (137)	3-3/4 (95)	5-3/8 (137)	3-3/4 (95)	5-3/8 (137)	3-3/4 (95)	5-3/8 (137)	3-3/4 (95)	5-3/8 (137)	3-3/4 (95)	5-3/8 (137)
Spacing (s) / edge distance (c_e) / concrete thickness (h) - in. (mm)	5 (127)	0.76	n/a	0.45	n/a	0.58	n/a	0.31	n/a	0.45	n/a	n/a	n/a
	5-1/2 (140)	0.78	n/a	0.50	n/a	0.58	n/a	0.35	n/a	0.50	n/a	n/a	n/a
	6 (152)	0.81	0.71	0.55	0.39	0.59	0.56	0.40	0.23	0.55	0.39	0.60	n/a
	6-1/2 (165)	0.83	0.73	0.59	0.41	0.60	0.57	0.45	0.26	0.59	0.41	0.63	n/a
	7 (178)	0.86	0.75	0.64	0.44	0.61	0.57	0.51	0.29	0.64	0.44	0.65	n/a
	8 (203)	0.91	0.78	0.73	0.50	0.62	0.58	0.62	0.35	0.73	0.50	0.70	n/a
	9 (229)	0.96	0.82	0.82	0.56	0.64	0.59	0.74	0.42	0.82	0.56	0.74	n/a
	10 (254)	1.00	0.85	0.91	0.63	0.65	0.60	0.87	0.49	0.91	0.63	0.78	0.65
	11 (279)		0.89	1.00	0.69	0.67	0.61	1.00	0.57	1.00	0.69	0.82	0.68
	12 (305)		0.92		0.75	0.68	0.63		0.65		0.75	0.85	0.71
	14 (356)		0.99		0.88	0.71	0.65		0.82		0.88	0.92	0.76
	16 (406)		1.00		1.00	0.74	0.67		1.00		1.00	0.98	0.82
	18 (457)					0.77	0.69					1.00	0.87
	20 (508)					0.80	0.71						0.91
	22 (559)					0.83	0.73						0.96
	24 (610)					0.86	0.75						1.00
28 (711)					0.92	0.79							
36 (914)					1.00	0.88							
≥ 48 (1219)						1.00							

Table 13 – Load adjustment factors for 3/4-in. diameter Hilti Kwik Bolt VTZ in cracked concrete^{1,2}

3/4-in. KB-VTZ cracked concrete		Spacing factor in tension f_{AN}		Edge distance factor in tension f_{RN}		Spacing factor in shear ³ f_{AV}		Edge distance in shear				Conc. thickness factor in shear ⁴ f_{HV}	
								⊥ toward edge f_{RV}		to and away from edge f_{RV}			
Effective embed. h_{ef}	in. (mm)	3-1/4 (83)	4-3/4 (121)	3-1/4 (83)	4-3/4 (121)	3-1/4 (83)	4-3/4 (121)	3-1/4 (83)	4-3/4 (121)	3-1/4 (83)	4-3/4 (121)	3-1/4 (83)	4-3/4 (121)
Nominal embed. h_{nom}	in. (mm)	3-3/4 (95)	5-3/8 (137)	3-3/4 (95)	5-3/8 (137)	3-3/4 (95)	5-3/8 (137)	3-3/4 (95)	5-3/8 (137)	3-3/4 (95)	5-3/8 (137)	3-3/4 (95)	5-3/8 (137)
Spacing (s) / edge distance (c_e) / concrete thickness (h) - in. (mm)	5 (127)	0.77	n/a	1.00	n/a	0.59	n/a	0.39	n/a	0.78	n/a	n/a	n/a
	5-1/2 (140)	0.79	n/a	1.00	n/a	0.60	n/a	0.45	n/a	0.90	n/a	n/a	n/a
	6 (152)	0.82	0.71	1.00	0.88	0.61	0.59	0.51	0.37	1.00	0.73	0.65	n/a
	6-1/2 (165)	0.85	0.73		0.93	0.62	0.59	0.58	0.41		0.83	0.68	n/a
	7 (178)	0.87	0.75		0.99	0.62	0.60	0.64	0.46		0.92	0.71	n/a
	8 (203)	0.93	0.78		1.00	0.64	0.61	0.79	0.56		1.00	0.75	n/a
	9 (229)	0.98	0.82			0.66	0.63	0.94	0.67			0.80	n/a
	10 (254)	1.00	0.85			0.68	0.64	1.00	0.79			0.84	0.75
	11 (279)		0.89			0.70	0.66		0.91			0.88	0.79
	12 (305)		0.92			0.71	0.67		1.00			0.92	0.83
	14 (356)		0.99			0.75	0.70					1.00	0.89
	16 (406)		1.00			0.78	0.73					1.00	0.95
	18 (457)					0.82	0.76						1.00
	20 (508)					0.86	0.78						
	22 (559)					0.89	0.81						
	24 (610)					0.93	0.84						
28 (711)					1.00	0.90							
≥ 36 (914)						1.00							

1 Linear interpolation not permitted.

2 These values are applicable for groups of up to four anchors with all factors applied in both directions. When combining multiple load adjustment factors (e.g., for a 4 anchor pattern in a corner with thin concrete member) the design can become very conservative. To optimize the design, and for groups of greater than four anchors use Hilti PROFIS Anchor Design software or perform anchor calculation using design equations from ACI 318-14 Chapter 17.

3 Spacing factor reduction in shear, f_{AV} , assumes an influence of a nearby edge. If no edge exists, $f_{AV} = f_{AN}$.

4 Concrete thickness reduction factor in shear, f_{HV} , assumes an influence of a nearby edge. If no edge exists, $f_{HV} = 1.0$.

☐ If a reduction factor value is in a shaded cell, this indicates that this specific edge distance may not be permitted with a certain spacing (or vice versa). Check with table 5 and figure 2 to calculate permissible edge distance, spacing, and concrete thickness combinations.

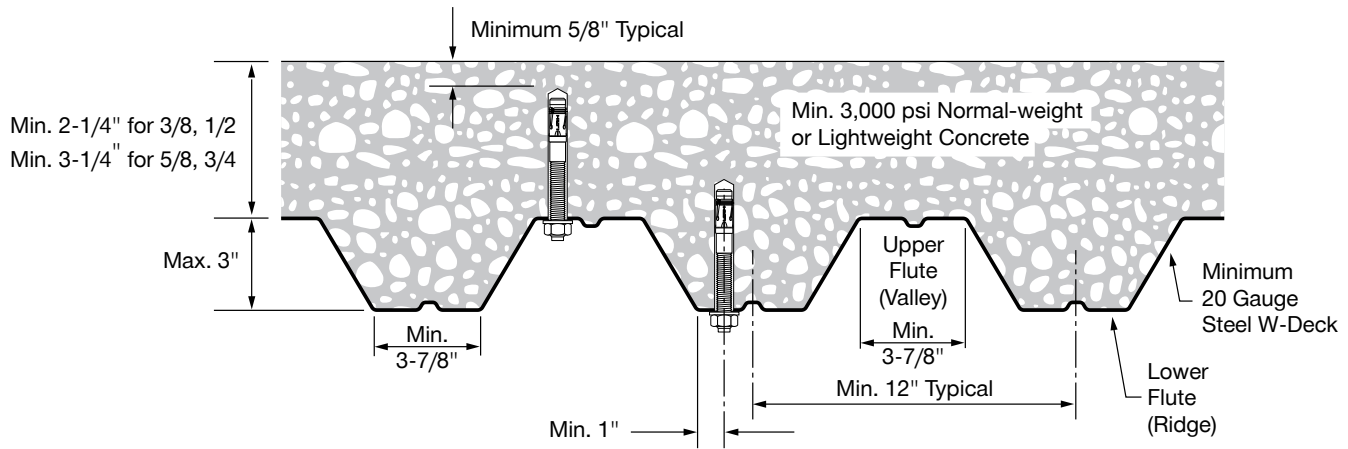

Figure 4 – Installation of Hilti Kwik Bolt VTZ in the soffit of concrete over metal deck floor and roof assemblies – W Deck

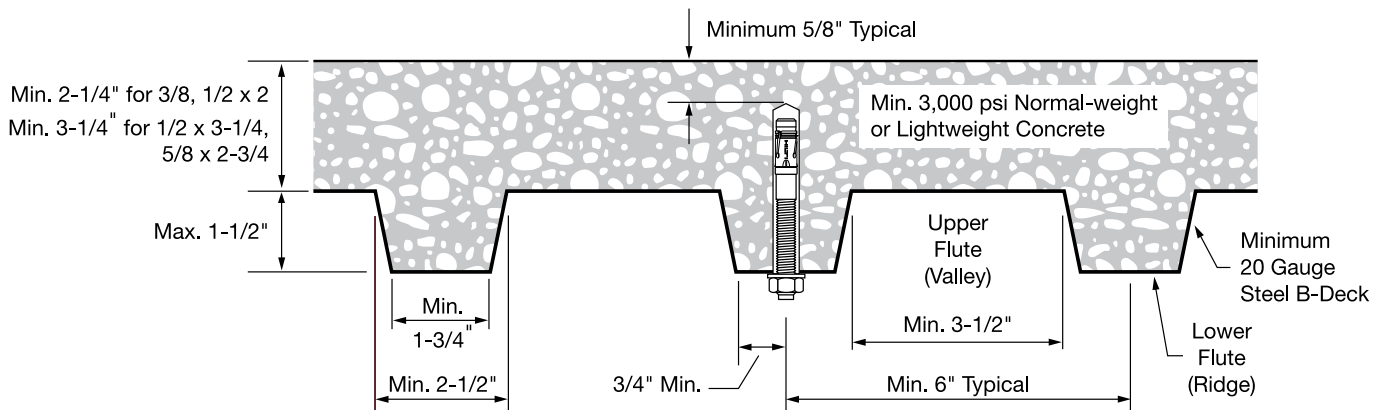

Figure 5 – Installation of Hilti Kwik Bolt VTZ in the soffit of concrete over metal deck floor and roof assemblies – B Deck

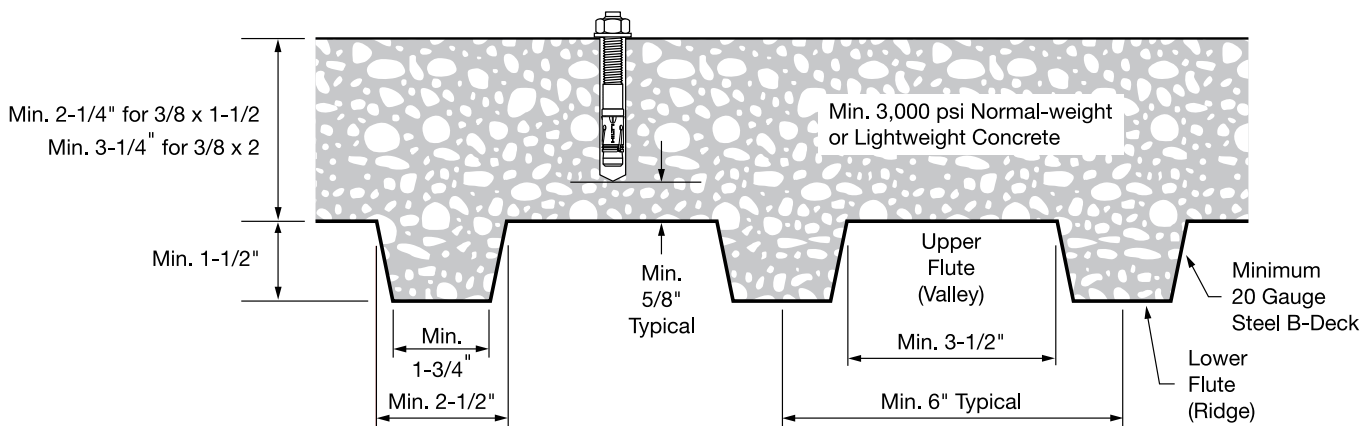

Figure 6 – Installation of the Hilti Kwik Bolt VTZ on the top of concrete over metal deck floor and roof assemblies

Table 14 — Hilti Kwik Bolt VTZ design strength in the soffit of uncracked lightweight concrete over metal deck^{1,2,3,4,5,6}

Nominal anchor diameter in. (mm)	Effective embed. in. (mm)	Nominal embed. in. (mm)	Tension - ϕN_n		Shear - ϕV_n		Tension - ϕN_n		Shear - ϕV_n	
			$f'_c = 3,000$ psi (20.7 MPa) lb (kN)	$f'_c = 4,000$ psi (27.6 MPa) lb (kN)	$f'_c = 3,000$ psi (20.7 MPa) lb (kN)	$f'_c = 4,000$ psi (27.6 MPa) lb (kN)	$f'_c = 3,000$ psi (20.7 MPa) lb (kN)	$f'_c = 4,000$ psi (27.6 MPa) lb (kN)	$f'_c = 3,000$ psi (20.7 MPa) lb (kN)	$f'_c = 4,000$ psi (27.6 MPa) lb (kN)
3/8	1-1/2 (38)	1-13/16 (46)	755 (3.4)	870 (3.9)	995 (4.4)	995 (4.4)	765 (3.4)	885 (3.9)	1,140 (5.1)	1,140 (5.1)
	2 (51)	2-5/16 (59)	1,305 (5.8)	1,505 (6.7)	1,175 (5.2)	1,175 (5.2)	1,000 (4.4)	1,155 (5.1)	1,660 (7.4)	1,660 (7.4)
1/2	2 (51)	2-1/2 (64)	1,105 (4.9)	1,275 (5.7)	1,625 (7.2)	1,625 (7.2)	1,215 (5.4)	1,405 (6.2)	1,350 (6.0)	1,350 (6.0)
	3-1/4 (83)	3-3/4 (95)	2,065 (9.2)	2,385 (10.6)	2,745 (12.2)	2,745 (12.2)	1,750 (7.8)	2,020 (9.0)	2,270 (10.1)	2,270 (10.1)
5/8	2-3/4 (70)	3-5/16 (84)	1,565 (7.0)	1,805 (8.0)	2,390 (10.6)	2,390 (10.6)	1,545 (6.9)	1,785 (7.9)	1,500 (6.7)	1,500 (6.7)
	4 (102)	4-9/16 (116)	1,565 (7.0)	1,805 (8.0)	2,390 (10.6)	2,390 (10.6)	n/a	n/a	n/a	n/a
3/4	3-1/8 (83)	3-3/4 (95)	2,310 (10.3)	2,665 (11.9)	1,955 (8.7)	1,955 (8.7)	n/a	n/a	n/a	n/a
	4-3/4 (121)	5-3/8 (137)	2,310 (10.3)	2,665 (11.9)	1,955 (8.7)	1,955 (8.7)	n/a	n/a	n/a	n/a

Table 15 — Hilti Kwik Bolt VTZ design strength in the soffit of cracked lightweight concrete over metal deck^{1,2,3,4,5,6,7}

Nominal anchor diameter in. (mm)	Effective embed. in. (mm)	Nominal embed. in. (mm)	Tension - ϕN_n		Shear - ϕV_n		Tension - ϕN_n		Shear - ϕV_n	
			$f'_c = 3,000$ psi (20.7 MPa) lb (kN)	$f'_c = 4,000$ psi (27.6 MPa) lb (kN)	$f'_c = 3,000$ psi (20.7 MPa) lb (kN)	$f'_c = 4,000$ psi (27.6 MPa) lb (kN)	$f'_c = 3,000$ psi (20.7 MPa) lb (kN)	$f'_c = 4,000$ psi (27.6 MPa) lb (kN)	$f'_c = 3,000$ psi (20.7 MPa) lb (kN)	$f'_c = 4,000$ psi (27.6 MPa) lb (kN)
3/8	1-1/2 (38)	1-13/16 (46)	425 (1.9)	490 (2.2)	995 (4.4)	995 (4.4)	430 (1.9)	495 (2.2)	1,140 (5.1)	1,140 (5.1)
	2 (51)	2-5/16 (59)	1,075 (4.8)	1,240 (5.5)	1,175 (5.2)	1,175 (5.2)	820 (3.6)	945 (4.2)	1,660 (7.4)	1,660 (7.4)
1/2	2 (51)	2-1/2 (64)	870 (3.9)	1,005 (4.5)	1,625 (7.2)	1,625 (7.2)	955 (4.2)	1,105 (4.9)	1,350 (6.0)	1,350 (6.0)
	3-1/4 (83)	3-3/4 (95)	1,235 (5.5)	1,425 (6.3)	2,745 (12.2)	2,745 (12.2)	1,040 (4.6)	1,200 (5.3)	2,270 (10.1)	2,270 (10.1)
5/8	2-3/4 (70)	3-5/16 (84)	1,255 (5.6)	1,450 (6.4)	2,390 (10.6)	2,390 (10.6)	1,240 (5.5)	1,430 (6.4)	1,500 (6.7)	1,500 (6.7)
	4 (102)	4-9/16 (116)	1,215 (5.4)	1,405 (6.2)	2,390 (10.6)	2,390 (10.6)	n/a	n/a	n/a	n/a
3/4	3-1/8 (83)	3-3/4 (95)	1,925 (8.6)	2,225 (9.9)	1,955 (8.7)	1,955 (8.7)	n/a	n/a	n/a	n/a
	4-3/4 (121)	5-3/8 (137)	1,925 (8.6)	2,225 (9.9)	1,955 (8.7)	1,955 (8.7)	n/a	n/a	n/a	n/a

- 1 See the Hilti North America Anchor Fastening Technical Guide to convert design strength value to ASD value.
- 2 Linear interpolation between embedment depths and concrete compressive strengths is not permitted.
- 3 Tabular value is for one anchor per flute. Minimum spacing along the length of the flute is $3 \times h_{ef}$ (effective embedment).
- 4 No additional reduction factor is needed for lightweight concrete.
- 5 No additional reduction factors for spacing or edge distance need to be applied.
- 6 Comparison to steel values in table 2 is not required. Values in tables 14 and 15 control.
- 7 Tabular values are for static loads only. Seismic design is not permitted for uncracked concrete. For seismic tension loads, multiply cracked concrete tabular values in tension only by $\alpha_{N,seis} = 0.75$. See the Hilti North America Anchor Fastening Technical Guide for additional information on seismic applications.

Table 16 — Hilti Kwik Bolt VTZ design strength in the top of uncracked concrete over metal deck^{1,2,3,4,5}

Nominal anchor diameter in.	Effective embed. in. (mm)	Nominal embed. in. (mm)	Tension - ϕN_n		Shear - ϕV_n	
			$f'_c = 3,000$ psi lb (kN)	$f'_c = 4,000$ psi lb (kN)	$f'_c = 3,000$ psi lb (kN)	$f'_c = 4,000$ psi lb (kN)
3/8	1-1/2 (38)	1-13/16 (46)	1,510 (6.7)	1,745 (7.8)	1,690 (7.5)	1,950 (8.7)
	2 (51)	2-5/16 (59)	1,775 (7.9)	2,045 (9.1)	2,605 (11.6)	3,005 (13.4)

Table 17 — Hilti Kwik Bolt VTZ design strength in the top of cracked concrete over metal deck^{1,2,3,4,5}

Nominal anchor diameter in.	Effective embed. in. (mm)	Nominal embed. in. (mm)	Tension - ϕN_n		Shear - ϕV_n	
			$f'_c = 3,000$ psi lb (kN)	$f'_c = 4,000$ psi lb (kN)	$f'_c = 3,000$ psi lb (kN)	$f'_c = 4,000$ psi lb (kN)
3/8	1-1/2 (38)	1-13/16 (46)	845 (3.8)	980 (4.4)	1,195 (5.3)	1,385 (6.2)
	2 (51)	2-5/16 (59)	1,455 (6.5)	1,675 (7.5)	1,845 (8.2)	2,130 (9.5)

- 1 See the Hilti North America Anchor Fastening Technical Guide to convert design strength value to ASD value.
- 2 Linear interpolation between embedment depths and concrete compressive strengths is not permitted.
- 3 Apply spacing, edge distance, and concrete thickness factors in tables 18 and 19 as necessary. Compare to the steel values in table 2; The lesser of the values is to be used for the design.
- 4 Tabular values are for normal weight concrete only. For lightweight concrete multiply design strength by λ_a as follows:
for sand-lightweight, $\lambda_a = 0.68$; for all-lightweight, $\lambda_a = 0.60$
- 5 Tabular values are for static loads only. Seismic design is not permitted for uncracked concrete. For seismic tension loads, multiply cracked concrete tabular values in tension only by $\alpha_{N,seis} = 0.75$. See the Hilti North America Anchor Fastening Technical Guide for additional information on seismic applications.

Table 18 – Load adjustment factors for Hilti Kwik Bolt VTZ in the top of uncracked concrete over metal deck^{1,2}

3/8-in. and 1/2-in. KB-VTZ CS uncracked concrete over metal deck		Spacing factor in tension f_{AN}		Edge distance factor in tension f_{RN}		Spacing factor in shear ³ f_{AV}		Edge distance in shear				Conc. thickness factor in shear ⁴ f_{HV}	
								⊥ toward edge f_{RV}		to and away from edge f_{RV}			
Effective embed. h_{ef}	in. (mm)	1-1/2 (38)	2 (51)	1-1/2 (38)	2 (51)	1-1/2 (38)	2 (51)	1-1/2 (38)	2 (51)	1-1/2 (38)	2 (51)	1-1/2 (38)	2 (51)
Nominal embed. h_{nom}	in. (mm)	1-13/16 (46)	2-5/16 (59)	1-13/16 (46)	2-5/16 (59)	1-13/16 (46)	2-5/16 (59)	1-13/16 (46)	2-5/16 (59)	1-13/16 (46)	2-5/16 (59)	1-13/16 (46)	2-5/16 (59)
Spacing (s)/edge distance (c_p)/concrete thickness (t) - in. (mm)	2-1/4 (57)	n/a	n/a	n/a	n/a	n/a	n/a	n/a	n/a	n/a	n/a	0.50	n/a
	2-1/2 (64)	n/a	n/a	n/a	n/a	n/a	n/a	n/a	n/a	n/a	n/a	0.53	n/a
	2-3/4 (70)	n/a	n/a	n/a	0.56	n/a	n/a	n/a	0.41	n/a	0.56	0.55	n/a
	3 (76)	n/a	n/a	n/a	0.60	n/a	n/a	n/a	0.46	n/a	0.60	0.58	n/a
	3-1/4 (83)	n/a	n/a	n/a	0.65	n/a	n/a	n/a	0.52	n/a	0.65		0.66
	3.5 (89)	n/a	n/a	n/a	0.70	n/a	n/a	n/a	0.59	n/a	0.70		0.68
	4 (102)	n/a	n/a	n/a	0.80	n/a	n/a	n/a	0.72	n/a	0.80		
	5 (127)	n/a	n/a	n/a	1.00	n/a	n/a	n/a	1.00	n/a	1.00		
	5-1/2 (140)	1.00	n/a	n/a		0.65	n/a	n/a					
	6 (152)		1.00	1.00		0.67	0.70	1.00			1.00		
	7 (178)					0.69	0.73						
	8 (203)					0.72	0.77						
	10 (254)					0.78	0.83						
	12 (305)					0.83	0.90						
14 (356)					0.89	0.97							
16 (406)					0.94	1.00							
24 (610)					1.00								

Table 19 – Load adjustment factors for Hilti Kwik Bolt VTZ in the top of cracked concrete over metal deck^{1,2}

3/8-in. and 1/2-in. KB-VTZ cracked concrete over metal deck		Spacing factor in tension f_{AN}		Edge distance factor in tension f_{RN}		Spacing factor in shear ³ f_{AV}		Edge distance in shear				Conc. thickness factor in shear ⁴ f_{HV}	
								⊥ toward edge f_{RV}		to and away from edge f_{RV}			
Effective embed. h_{ef}	in. (mm)	1-1/2 (38)	2 (51)	1-1/2 (38)	2 (51)	1-1/2 (38)	2 (51)	1-1/2 (38)	2 (51)	1-1/2 (38)	2 (51)	1-1/2 (38)	2 (51)
Nominal embed. h_{nom}	in. (mm)	1-13/16 (46)	2-5/16 (59)	1-13/16 (46)	2-5/16 (59)	1-13/16 (46)	2-5/16 (59)	1-13/16 (46)	2-5/16 (59)	1-13/16 (46)	2-5/16 (59)	1-13/16 (46)	2-5/16 (59)
Spacing (s)/edge distance (c_p)/concrete thickness (t) - in. (mm)	2-1/4 (57)	n/a	n/a	n/a	n/a	n/a	n/a	n/a	n/a	n/a	n/a	0.69	n/a
	2-1/2 (64)	n/a	n/a	n/a	n/a	n/a	n/a	n/a	n/a	n/a	n/a	0.73	n/a
	2-3/4 (70)	n/a	n/a	n/a	0.93	n/a	n/a	n/a	0.62	n/a	0.93	0.77	n/a
	3 (76)	n/a	n/a	n/a	1.00	n/a	n/a	n/a	0.71	n/a	1.00	0.80	n/a
	3-1/4 (83)	n/a	n/a	n/a		n/a	n/a	n/a	0.80	n/a			0.76
	3.5 (89)	n/a	n/a	n/a		n/a	n/a	n/a	0.89	n/a			0.79
	4 (102)	n/a	n/a	n/a		n/a	n/a	n/a	1.00	n/a			
	5 (127)	n/a	n/a	n/a		n/a	n/a	n/a		n/a			
	5-1/2 (140)	1.00	n/a	n/a		0.79	n/a	n/a			n/a		
	6 (152)		1.00	1.00		0.82	0.76	1.00			1.00		
	7 (178)					0.87	0.81						
	8 (203)					0.93	0.85						
	10 (254)					1.00	0.94						
	12 (305)						1.00						

1 Linear interpolation not permitted.

2 These values are applicable for groups of up to four anchors with all factors applied in both directions. When combining multiple load adjustment factors (e.g., for a 4 anchor pattern in a corner with thin concrete member) the design can become very conservative. To optimize the design, use Hilti PROFIS Anchor Design software or perform anchor calculation using design equations from ACI 318-14 Chapter 17.

3 Spacing factor reduction in shear, f_{AV} , assumes an influence of a nearby edge. If no edge exists, then $f_{AV} = f_{AN}$.

4 Concrete thickness reduction factor in shear, f_{HV} , assumes an influence of a nearby edge. If no edge exists, then $f_{HV} = 1.0$.

For concrete thickness greater than or equal to the minimum thickness given in Table 5, the anchor can be designed using table 3 along with the corresponding load reduction factor table for concrete design.

3.2 Canadian Limit State design

Limit State Design of anchors is described in the provisions of CSA A23.3-14 Annex D for post-installed anchors tested and assessed in accordance with ACI 355.2 for mechanical anchors and ACI 355.4 for adhesive anchors. This section contains the Limit State Design tables with unfactored characteristic loads that are based on the published loads in ICC Evaluation Services ESR-3904. These tables are followed by factored resistance tables. The factored resistance tables have characteristic design loads that are prefactored by the applicable reduction factors for a single anchor with no anchor-to-anchor spacing or edge distance adjustments for the convenience of the user of this document. All the figures in the previous ACI 318-14 Chapter 17 design section are applicable to Limit State Design and the tables will reference these figures.

For a detailed explanation of the tables developed in accordance with CSA A23.3-14 Annex D, refer to the Hilti North America Anchor Fastening Technical Guide. Technical assistance is available by contacting Hilti Canada at (800) 363-4458 or at www.hilti.ca

Table 20 — Steel resistance for Hilti Kwik Bolt VTZ anchors^{1,2}



Nominal anchor diameter in.	Effective anchor embedment in. (mm)		Tensile N_{sar} ³ lb (kN)	Shear V_{sar} ⁴ lb (kN)	Seismic shear $V_{sar,eq}$ ⁵ lb (kN)
3/8	1-1/2 (38)		4,080 (18.1)	1,230 (5.5)	1,230 (5.5)
	2 (51)		4,080 (18.1)	1,740 (7.7)	1,580 (7.0)
1/2	2 (51)	3-1/4 (83)	7,325 (32.6)	2,945 (13.1)	2,945 (13.1)
5/8	2-3/4 (70)	4 (102)	11,240 (50.0)	5,650 (25.1)	3,850 (17.1)
3/4	3-1/8 (83)		15,335 (68.2)	6,585 (29.3)	5,745 (25.6)
	4-3/4 (121)		15,335 (68.2)	6,770 (30.1)	6,575 (29.2)

1 See the Hilti North America Anchor Fastening Technical Guide to convert design strength value to ASD value.

2 Hilti Kwik Bolt VTZ anchors are permitted to be considered ductile steel elements as defined by ACI 318-14 Section 2.3.

3 Tensile $N_{sar} = A_{se,N} \phi_s f_{uta} R$ as noted in CSA A23.3-14, Annex D.

4 Shear determined by static shear tests with $V_{sar} < A_{se,V} \phi_s 0.6 f_{uta} R$ as noted in CSA A23.3-14, Annex D.

5 Seismic shear values determined by seismic shear tests with $V_{sar,eq} < A_{se,V} \phi_s 0.6 f_{uta} R$ as noted in CSA A23.3-14, Annex D. See the Hilti North America Anchor Fastening Technical Guide for additional information on seismic applications.

Table 21 – Hilti Kwik Bolt VTZ design information in accordance with CSA A23.3-14¹

Design parameter	Symbol	Units	Nominal anchor diameter								Ref
			3/8		1/2		5/8		3/4		
Anchor O.D.	d_a	in. (mm)	0.375 (9.5)		0.5 (12.7)		0.625 (15.9)		0.75 (19.1)		
Effective minimum embedment ²	h_{ef}	in. (mm)	1-1/2 (38)	2 (51)	2 (51)	3-1/4 (83)	2-3/4 (70)	4 (102)	3-1/8 (79)	4-3/4 (121)	
Min. member thickness ³	h_{min}	in. (mm)	3-1/4 (83)	4 (102)	4 (102)	6 (152)	6 (152)	7 (178)	6 (152)	10 (254)	
Critical edge distance	c_{ac}	in. (mm)	6 (152)	8 (203)	8 (203)	5 (127)	6 (152)	9 (229)	11 (279)	16 (406)	
Min. edge distance	$c_{min,1} \geq$	in. (mm)	2-3/4 (70)	2-1/4 (57)	3-1/4 (83)	2-3/4 (70)	5-1/2 (140)	4-1/4 (108)	5 (127)	6 (152)	
	$s_{min,1} \geq$	in. (mm)	9 (229)	3-3/4 (95)	10 (254)	6 (152)	11 (279)	4-1/4 (108)	6 (152)	6-1/2 (165)	
Min. anchor spacing	$s_{min,2}$	in. (mm)	3-1/2 (89)	3-3/4 (95)	4-1/2 (114)	4 (102)	6-1/2 (165)	4 (108)	5 (127)	6 (152)	
	$c_{min,2} \geq$	in. (mm)	6 (152)	5-1/4 (133)	6 (152)	5 (127)	6-1/2 (165)	4-1/4 (108)	6 (152)	6-1/2 (165)	
Min. hole depth in concrete	h_o	in. (mm)	2 (51)	2-1/2 (64)	2-3/4 (70)	4 (102)	3-5/8 (92)	4-7/8 (124)	4-1/16 (103)	5-11/16 (144)	
Min. specified yield strength	f_{ya}	psi (N/mm ²)	89,500 (617)		83,500 (576)		83,500 (576)		75,500 (521)		
Min. specified ult. strength	f_{uta}	psi (N/mm ²)	111,500 (769)		104,500 (721)		104,500 (721)		94,500 (652)		
Effective tensile stress area	$A_{se,N}$	in ² (mm ²)	0.054 (34.7)		0.103 (66.5)		0.158 (104)		0.239 (154)		
Steel embed. material resistance factor for reinforcement	Φ_s	-	0.85								8.4.3
Resistance modification factor for tension, steel failure modes ⁴	R	-	0.80								D.5.3
Resistance modification factor for shear, steel failure modes ⁴	R	-	0.75								D.5.3
Factored steel resistance in tension	N_{sar}	lb (kN)	4,080 (18.1)		7,325 (32.6)		11,240 (50.0)		15,335 (68.2)		D.6.1.2
Factored steel resistance in shear	V_{sar}	lb (kN)	1,230 (5.5)	1,740 (7.7)	2,945 (13.1)		5,650 (25.1)		6,585 (29.3)	6,770 (30.1)	D.7.1.2
Factored steel resistance in shear, seismic	$V_{sar,eq}$	lb (kN)	1,230 (5.5)	1,580 (7.0)	2,945 (13.1)		3,850 (17.1)		5,745 (25.6)	6,575 (29.2)	
Coeff. for factored concrete breakout resistance, uncracked concrete	$k_{c,uncr}$	-	10								D.6.2.2
Coeff. for factored concrete breakout resistance, cracked concrete	$k_{c,cr}$	-	7								D.6.2.2
Modification factor for anchor resistance, tension, uncracked concrete ⁵	$\psi_{c,N}$	-	1.0								D.6.2.6
Anchor category	-	-	1								D.5.3 (c)
Concrete material resistance factor	Φ_c	-	0.65								8.4.2
Resistance modification factor for tension and shear, concrete failure modes, Condition B ⁶	R	-	1								D.5.3 (c)
Factored pullout resistance in 20 MPa uncracked concrete ⁷	$N_{pr,uncr}$	lb (kN)	1,485 (6.6)	1,745 (7.8)	2,135 (9.5)	3,825 (17.0)	3,380 (15.0)	4,420 (19.7)	NA	7,400 (32.9)	D.6.3.2
Factored pullout resistance in 20 MPa cracked concrete ⁷	$N_{pr,cr}$	lb (kN)	835 (3.7)	1,430 (6.4)	NA	2,285 (10.2)	NA	3,430 (15.3)	NA	NA	D.6.3.2

1 Design information in this table is taken from ICC-ES ESR-3904, and converted for use with CSA A23.3-14 Annex D.

2 See figure 1.

3 For concrete over metal deck applications where the concrete thickness over the top flute is less than h_{min} in this table, see figure 6 and tables 26 and 27.

4 The Kwik Bolt VTZ is considered a ductile steel element as defined by CSA A23.3-14 Annex D section D.2.

5 For all design cases, $\psi_{c,N} = 1.0$. The appropriate coefficient for breakout resistance for cracked concrete ($k_{c,cr}$) or uncracked concrete ($k_{c,uncr}$) must be used.

6 For use with the load combinations of CSA A23.3-14 chapter 8. Condition B applies where supplementary reinforcement in conformance with CSA A23.3-14 section D.5.3 is not provided, or where pullout or pryout strength governs. For cases where the presence of supplementary reinforcement can be verified, the resistance modification factors associated with Condition A may be used.

7 For all design cases, $\psi_{c,p} = 1.0$. NA (not applicable) denotes that this value does not control for design. See ESR-3904 for additional information.

Table 22 — Hilti Kwik Bolt VTZ factored resistance with concrete/pullout failure in uncracked concrete^{1,2,3,4}

Nominal anchor diameter in. (mm)	Effective embed. in. (mm)	Nominal embed. in. (mm)	Tension - N_t				Shear - V_r			
			$f'_c = 20$ MPa (2,900 psi) lb (kN)	$f'_c = 25$ MPa (3,625 psi) lb (kN)	$f'_c = 30$ MPa (4,350 psi) lb (kN)	$f'_c = 40$ MPa (5,800 psi) lb (kN)	$f'_c = 20$ MPa (2,900 psi) lb (kN)	$f'_c = 25$ MPa (3,625 psi) lb (kN)	$f'_c = 30$ MPa (4,350 psi) lb (kN)	$f'_c = 40$ MPa (5,800 psi) lb (kN)
3/8	1-1/2 (38)	1-13/16 (46)	1,485 (6.6)	1,660 (7.4)	1,820 (8.1)	2,100 (9.3)	1,535 (6.8)	1,720 (7.6)	1,880 (8.4)	2,175 (9.7)
	2 (51)	2-5/16 (59)	1,745 (7.8)	1,950 (8.7)	2,135 (9.5)	2,465 (11.0)	2,365 (10.5)	2,645 (11.8)	2,900 (12.9)	3,345 (14.9)
1/2	2 (51)	2-1/2 (64)	2,135 (9.5)	2,390 (10.6)	2,615 (11.6)	3,020 (13.4)	2,365 (10.5)	2,645 (11.8)	2,900 (12.9)	3,345 (14.9)
	3-1/4 (83)	3-3/4 (95)	3,825 (17.0)	4,275 (19.0)	4,685 (20.8)	5,405 (24.1)	9,805 (43.6)	10,960 (48.8)	12,005 (53.4)	13,865 (61.7)
5/8	2-3/4 (70)	3-5/16 (84)	3,380 (15.0)	3,780 (16.8)	4,140 (18.4)	4,785 (21.3)	7,630 (33.9)	8,530 (37.9)	9,345 (41.6)	10,790 (48.0)
	4 (102)	4-9/16 (116)	4,420 (19.7)	4,940 (22.0)	5,410 (24.1)	6,250 (27.8)	13,385 (59.5)	14,965 (66.6)	16,395 (72.9)	18,930 (84.2)
3/4	3-1/8 (83)	3-3/4 (95)	4,620 (20.6)	5,165 (23.0)	5,660 (25.2)	6,535 (29.1)	9,245 (41.1)	10,335 (46.0)	11,320 (50.4)	13,070 (58.1)
	4-3/4 (121)	5-3/8 (137)	7,400 (32.9)	8,275 (36.8)	9,065 (40.3)	10,470 (46.6)	17,320 (77.0)	19,365 (86.1)	21,215 (94.4)	24,495 (109.0)

Table 23 — Hilti Kwik Bolt VTZ factored resistance with concrete/pullout failure in cracked concrete^{1,2,3,4,5}

Nominal anchor diameter in. (mm)	Effective embed. in. (mm)	Nominal embed. in. (mm)	Tension - N_t				Shear - V_r			
			$f'_c = 20$ MPa (2,900 psi) lb (kN)	$f'_c = 25$ MPa (3,625 psi) lb (kN)	$f'_c = 30$ MPa (4,350 psi) lb (kN)	$f'_c = 40$ MPa (5,800 psi) lb (kN)	$f'_c = 20$ MPa (2,900 psi) lb (kN)	$f'_c = 25$ MPa (3,625 psi) lb (kN)	$f'_c = 30$ MPa (4,350 psi) lb (kN)	$f'_c = 40$ MPa (5,800 psi) lb (kN)
3/8	1-1/2 (38)	1-13/16 (46)	835 (3.7)	930 (4.1)	1,020 (4.5)	1,180 (5.2)	1,075 (4.8)	1,205 (5.4)	1,320 (5.9)	1,520 (6.8)
	2 (51)	2-5/16 (59)	1,430 (6.4)	1,595 (7.1)	1,750 (7.8)	2,020 (9.0)	1,655 (7.4)	1,850 (8.2)	2,030 (9.0)	2,340 (10.4)
1/2	2 (51)	2-1/2 (64)	1,655 (7.4)	1,850 (8.2)	2,030 (9.0)	2,340 (10.4)	1,655 (7.4)	1,850 (8.2)	2,030 (9.0)	2,340 (10.4)
	3-1/4 (83)	3-3/4 (95)	2,285 (10.2)	2,550 (11.4)	2,795 (12.4)	3,230 (14.4)	6,860 (30.5)	7,670 (34.1)	8,405 (37.4)	9,705 (43.2)
5/8	2-3/4 (70)	3-5/16 (84)	2,670 (11.9)	2,985 (13.3)	3,270 (14.5)	3,775 (16.8)	5,340 (23.8)	5,970 (26.6)	6,540 (29.1)	7,555 (33.6)
	4 (102)	4-9/16 (116)	3,430 (15.3)	3,835 (17.1)	4,205 (18.7)	4,855 (21.6)	9,370 (41.7)	10,475 (46.6)	11,475 (51.0)	13,250 (58.9)
3/4	3-1/8 (83)	3-3/4 (95)	3,235 (14.4)	3,615 (16.1)	3,960 (17.6)	4,575 (20.4)	6,470 (28.8)	7,235 (32.2)	7,925 (35.2)	9,150 (40.7)
	4-3/4 (121)	5-3/8 (137)	6,060 (27.0)	6,780 (30.1)	7,425 (33.0)	8,575 (38.1)	12,125 (53.9)	13,555 (60.3)	14,850 (66.1)	17,145 (76.3)

1 See the Hilti North America Anchor Fastening Technical Guide to convert design strength value to ASD value.

2 Linear interpolation between embedment depths and concrete compressive strengths is not permitted.

3 Apply spacing, edge distance, and concrete thickness factors in tables 6 through 13 as necessary. Compare to the steel values in table 20; the lesser of the values is to be used for the design.

4 Tabular values are for normal weight concrete only. For lightweight concrete multiply design strength by λ_a as follows: for sand-lightweight, $\lambda_a = 0.68$; for all-lightweight, $\lambda_a = 0.60$

5 Tabular values are for static loads only. Seismic design is not permitted for uncracked concrete. For seismic tension loads, multiply cracked concrete tabular values in tension only by $\alpha_{N,crack} = 0.75$. No seismic reduction needed for shear values in this table. See the Hilti North America Anchor Fastening Technical Guide for additional information on seismic applications.

Table 24 — Hilti Kwik Bolt VTZ factored resistance in the soffit of uncracked lightweight concrete over metal deck^{1,2,3,4,5,6,7}

Nominal anchor diameter in.	Effective embedment in. (mm)	Nominal embedment in. (mm)	Loads according to Figure 4			Loads according to Figure 5		
			Tension - N_r		Shear - V_r	Tension - N_r		Shear - V_r
			$f'_c = 20$ MPa (2,900 psi) lb (kN)	$f'_c = 30$ MPa (4,350 psi) lb (kN)	$f'_c = 20$ MPa (2,900 psi) lb (kN)	$f'_c = 20$ MPa (2,900 psi) lb (kN)	$f'_c = 30$ MPa (4,350 psi) lb (kN)	$f'_c = 20$ MPa (2,900 psi) lb (kN)
3/8	1-1/2 (38)	1-13/16 (46)	740 (3.3)	910 (4.0)	975 (4.3)	755 (3.4)	925 (4.1)	1,115 (5.0)
	2 (51)	2-5/16 (59)	1,285 (5.7)	1,575 (7.0)	1,155 (5.1)	985 (4.4)	1,205 (5.4)	1,625 (7.2)
1/2	2 (51)	2-1/2 (64)	1,085 (4.8)	1,330 (5.9)	1,595 (7.1)	1,195 (5.3)	1,465 (6.5)	1,325 (5.9)
	3-1/4 (83)	3-3/4 (95)	2,030 (9.0)	2,490 (11.1)	2,690 (12.0)	1,720 (7.7)	2,105 (9.4)	2,225 (9.9)
5/8	2-3/4 (70)	3-5/16 (84)	1,540 (6.9)	1,885 (8.4)	2,345 (10.4)	1,520 (6.8)	1,865 (8.3)	1,475 (6.6)
	4 (102)	4-9/16 (116)	1,540 (6.9)	1,885 (8.4)	2,345 (10.4)	n/a	n/a	n/a
3/4	3-1/8 (83)	3-3/4 (95)	2,270 (10.1)	2,780 (12.4)	1,920 (8.5)	n/a	n/a	n/a
	4-3/4 (121)	5-3/8 (137)	2,270 (10.1)	2,780 (12.4)	1,920 (8.5)	n/a	n/a	n/a

Table 25 — Hilti Kwik Bolt VTZ factored resistance in the soffit of cracked lightweight concrete over metal deck^{1,2,3,4,5,6,7}

Nominal anchor diameter in.	Effective embedment in. (mm)	Nominal embedment in. (mm)	Loads according to Figure 4			Loads according to Figure 5		
			Tension - N_r		Shear - V_r	Tension - N_r		Shear - V_r
			$f'_c = 20$ MPa (2,900 psi) lb (kN)	$f'_c = 30$ MPa (4,350 psi) lb (kN)	$f'_c = 20$ MPa (2,900 psi) lb (kN)	$f'_c = 20$ MPa (2,900 psi) lb (kN)	$f'_c = 30$ MPa (4,350 psi) lb (kN)	$f'_c = 20$ MPa (2,900 psi) lb (kN)
3/8	1-1/2 (38)	1-13/16 (46)	415 (1.8)	510 (2.3)	975 (4.3)	420 (1.9)	515 (2.3)	1,115 (5.0)
	2 (51)	2-5/16 (59)	1,055 (4.7)	1,290 (5.7)	1,155 (5.1)	805 (3.6)	985 (4.4)	1,625 (7.2)
1/2	2 (51)	2-1/2 (64)	855 (3.8)	1,050 (4.7)	1,595 (7.1)	940 (4.2)	1,150 (5.1)	1,325 (5.9)
	3-1/4 (83)	3-3/4 (95)	1,215 (5.4)	1,485 (6.6)	2,690 (12.0)	1,025 (4.6)	1,250 (5.6)	2,225 (9.9)
5/8	2-3/4 (70)	3-5/16 (84)	1,235 (5.5)	1,510 (6.7)	2,345 (10.4)	1,220 (5.4)	1,495 (6.7)	1,475 (6.6)
	4 (102)	4-9/16 (116)	1,195 (5.3)	1,465 (6.5)	2,345 (10.4)	n/a	n/a	n/a
3/4	3-1/8 (83)	3-3/4 (95)	1,890 (8.4)	2,315 (10.3)	1,920 (8.5)	n/a	n/a	n/a
	4-3/4 (121)	5-3/8 (137)	1,890 (8.4)	2,315 (10.3)	1,920 (8.5)	n/a	n/a	n/a

1 See the Hilti North America Anchor Fastening Technical Guide to convert design strength value to ASD value.

2 Linear interpolation between embedment depths and concrete compressive strengths is not permitted.

3 Tabular value is for one anchor per flute. Minimum spacing along the length of the flute is $3 \times h_{ef}$ (effective embedment).

4 No additional reduction factor is needed for lightweight concrete.

5 No additional reduction factors for spacing or edge distance need to be applied.

6 Comparison to steel values in table 20 is not required. Values in tables 24 and 25 control.

7 Tabular values are for static loads only. Seismic design is not permitted for uncracked concrete. For seismic tension loads, multiply cracked concrete tabular values in tension only by $\alpha_{N,seis} = 0.75$. See the Hilti North America Anchor Fastening Technical Guide for additional information on seismic applications.

Table 26 — Hilti Kwik Bolt VTZ factored resistance in the top of uncracked concrete over metal deck^{1,2,3,4,5}

Nominal anchor diameter in.	Effective embedment in. (mm)	Nominal embedment in. (mm)	Tension - N_r		Shear - V_r	
			$f'_c = 20$ MPa (2,900 psi) lb (kN)	$f'_c = 30$ MPa (4,350 psi) lb (kN)	$f'_c = 20$ MPa (2,900 psi) lb (kN)	$f'_c = 30$ MPa (4,350 psi) lb (kN)
3/8	1-1/2 (38)	1-13/16 (46)	1,485 (6.6)	1,820 (8.1)	1,535 (6.8)	1,880 (8.4)
	2 (51)	2-5/16 (59)	1,745 (7.8)	2,135 (9.5)	2,365 (10.5)	2,900 (12.9)

Table 27 — Hilti Kwik Bolt VTZ factored resistance in the top of cracked concrete over metal deck^{1,2,3,4,5}

Nominal anchor diameter in.	Effective embedment in. (mm)	Nominal embedment in. (mm)	Tension - N_r		Shear - V_r	
			$f'_c = 20$ MPa (2,900 psi) lb (kN)	$f'_c = 30$ MPa (4,350 psi) lb (kN)	$f'_c = 20$ MPa (2,900 psi) lb (kN)	$f'_c = 30$ MPa (4,350 psi) lb (kN)
3/8	1-1/2 (38)	1-13/16 (46)	835 (3.7)	1,020 (4.5)	1,075 (4.8)	1,320 (5.9)
	2 (51)	2-5/16 (59)	1,430 (6.4)	1,750 (7.8)	1,655 (7.4)	2,030 (9.0)

- 1 See the Hilti North America Anchor Fastening Technical Guide to convert design strength value to ASD value.
- 2 Linear interpolation between embedment depths and concrete compressive strengths is not permitted.
- 3 Apply spacing, edge distance, and concrete thickness factors in tables 18 and 19 as necessary. Compare to the steel values in table 20; the lesser of the values is to be used for the design.
- 4 Tabular values are for normal weight concrete only. For lightweight concrete multiply design strength by λ_a as follows: for sand-lightweight, $\lambda_a = 0.68$; for all-lightweight, $\lambda_a = 0.60$
- 5 Tabular values are for static loads only. Seismic design is not permitted for uncracked concrete. For seismic tension loads, multiply cracked concrete tabular values in tension only by $\alpha_{N,seis} = 0.75$. See the Hilti North America Anchor Fastening Technical Guide for additional information on seismic applications.

4 INSTALLATION INSTRUCTIONS

Installation Instructions For Use (IFU) are included with each product package. They can also be viewed or downloaded online at www.hilti.com (US) and www.hilti.ca (Canada). Because of the possibility of changes, always verify that downloaded IFU are current when used. Proper installation is critical to achieve full performance. Training is available on request. Contact Hilti Technical Services for applications and conditions not addressed in the IFU.

5 ORDERING INFORMATION¹

Description	Length	Threaded length	Box quantity
KB-VTZ 3/8x3	3	1-1/2	50
KB-VTZ 3/8x3-3/4	3-3/4	2-1/4	50
KB-VTZ 3/8x5	5	3-1/2	50
KB-VTZ 1/2x3-3/4	3-3/4	1-5/8	20
KB-VTZ 1/2x4-1/2	4-1/2	2-3/8	20
KB-VTZ 1/2x5-1/2	5-1/2	3-3/8	20
KB-VTZ 5/8x4-3/4	4-3/4	1-1/2	15
KB-VTZ 5/8x6	6	2-3/4	15
KB-VTZ 3/4x5-1/2	5-1/2	2-1/2	10
KB-VTZ 3/4x7	7	4	10

¹ All dimensions in inches

Table 28 — Kwik Bolt VTZ length identification system

Length ID marking on bolt head	A	B	C	D	E	F	G	H	I	J	K	L	M	N	O	P	Q	R	S	T	U	V	W
From	1 ½	2	2 ½	3	3 ½	4	4 ½	5	5 ½	6	6 ½	7	7 ½	8	8 ½	9	9 ½	10	11	12	13	14	15
Length of anchor, l_{anch} in. Up to but not including	2	2 ½	3	3 ½	4	4 ½	5	5 ½	6	6 ½	7	7 ½	8	8 ½	9	9 ½	10	11	12	13	14	15	16



Figure 7 — Bolt head with length identification mark and Kwik Bolt VTZ head notch embossment