



Classified by  
Underwriters Laboratories, Inc.  
to UL 1479 and CAN/ULC-S115

# System No. W-L-2537

WL 2537

ANSI/UL1479 (ASTM E814)	CAN/ULC S115
F Ratings — 1 and 2 Hr (See Item 1)	F Ratings — 1 and 2 Hr (See Item 1)
T Ratings — 0 and 1/4 Hr (See Item 3)	FT Ratings — 0 and 1/4 Hr (See Item 3)
	FH Ratings — 1 and 2 Hr (See Item 1)
	FTH Ratings — 0 and 1/4 Hr (See Item 3)

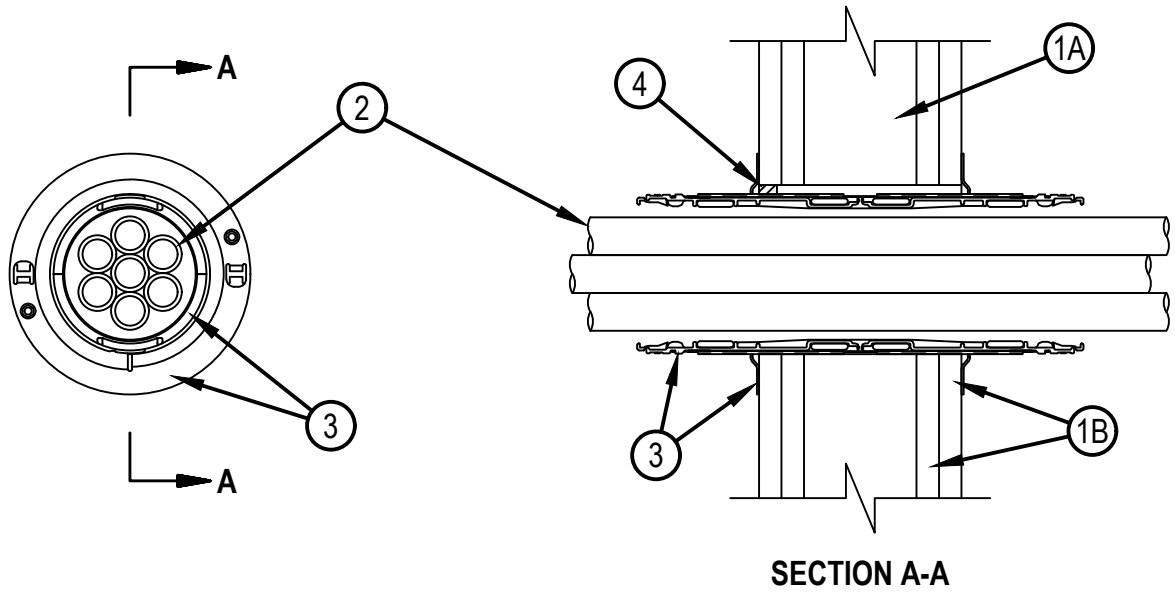

System tested with a pressure differential of 2.5 Pa between the exposed and the unexposed surfaces with the higher pressure on the exposed side.

1. Wall Assembly — The 1 or 2 hr fire-rated gypsum board/stud wall assembly shall be constructed of the materials and in the manner described within the individual U300, U400, V400 or W400 Series Wall and Partition Designs in the UL Fire Resistance Directory and shall incorporate the following construction features:

A. Studs — Wall framing shall consist of either wood studs or steel channel studs. Wood studs to consist of nom 2 by 4 in. (51 by 102 mm) lumber spaced max 16 in. (406 mm) OC. Steel studs to be min 3-1/2 in. (89 mm) wide and spaced max 24 in. (610 mm) OC.

B. Gypsum Board\* — Nom 5/8 in. (16 mm) thick gypsum board as specified in the individual Wall and Partition Design. Opening in gypsum board to be 2-1/2 in. (64 mm) diam for nominal 2 in. (51 mm) firestop device and 4 1/2 in. (114 mm) diam for nominal 4 in. (102 mm) firestop device.

The hourly F and FH Ratings of the firestop system are dependent upon the hourly rating of the wall in which it is installed. The hourly T, FT and FTH Ratings of the firestop system are 0 hr in 1 hr fire rated walls and 1/4 hr in 2 hr fire rated walls.

2. Cross Linked Polyethylene (PEX) Tubing — Nom 1 in. diam (or smaller) SDR9 PEX tubing for use in closed (process or supply) or vented (drain, waste or vent) piping systems. Within the loading area for each firestop device, the PEX tubes may represent a 0 to 100 percent visual fill. Tubing to be tightly bundled within the device and rigidly supported on both sides of wall assembly.

3. Firestop Device\* — Firestop device consists of a corrugated steel tube with an inner plastic housing, intumescent material rings, tightly twisted inner fabric smoke seal, flanges and gasketing material (not shown). As an option, the inner fabric seal may remain open. The T, FT and FTH Ratings of the firestop system are 0 hr when the inner fabric seal remains open. Firestop device to be installed in accordance with the accompanying installation instructions. Device slid into wall such that ends project an equal distance from the approximate centerline of the wall assembly. The annular space between the device and the periphery of the opening shall be min 0 in. (point contact). Device provided with flanges that are spun clockwise onto device threads, over gasketing material butting tightly to both sides of wall. As an alternate to gasket material, sealant (Item 4) may be used.



**Hilti Firestop Systems**

Reproduced by HILTI, Inc. Courtesy of  
Underwriters Laboratories, Inc.  
July 05, 2018

## System No. W-L-2537

WL 2537

HILTI CONSTRUCTION CHEMICALS, DIV OF HILTI INC — CP 653 and CP 653 BA 2" Speed Sleeve, CP 653 and CP 653 BA 4" Speed Sleeve, CFS-SL GAL Speed Sleeves, CP 653 4" BA ILS and CFS-SL GAL ILS Speed Sleeve

The CFS-SL GAL and CFS-SL GAL ILS Speed Sleeves shall only be used in wall thickness of 8 in. (203 mm) or greater.

4. Fill, Void or Cavity Material\* - Sealant — As an alternate to gasket material (see Item 3), min 1/2 in. (13 mm) thickness of fill material applied within the annulus between firestop device and wall, flush with both surfaces of wall. An additional 1/4 in. (6 mm) bead shall be applied around periphery of device on each side of wall prior to securing device flanges.

HILTI CONSTRUCTION CHEMICALS, DIV OF HILTI INC — CP 606 or FS-ONE MAX Intumescent Sealant

\* Indicates such products shall bear the UL or cUL Certification Mark for jurisdictions employing the UL or cUL Certification (such as Canada), respectively.



**Hilti Firestop Systems**

Reproduced by HILTI, Inc. Courtesy of  
Underwriters Laboratories, Inc.  
July 05, 2018