

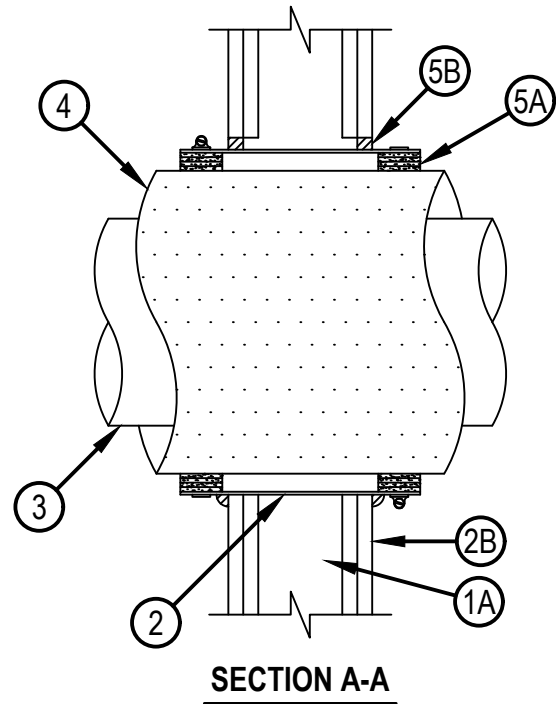

Classified by  
Underwriters Laboratories, Inc.  
to UL 1479

**System No. W-L-5347**  
**F Rating - 1 and 2 Hr (See Item 1)**  
**T Rating - 0, 1 and 2 Hr (See Items 4 and 4B)**

WL 5347

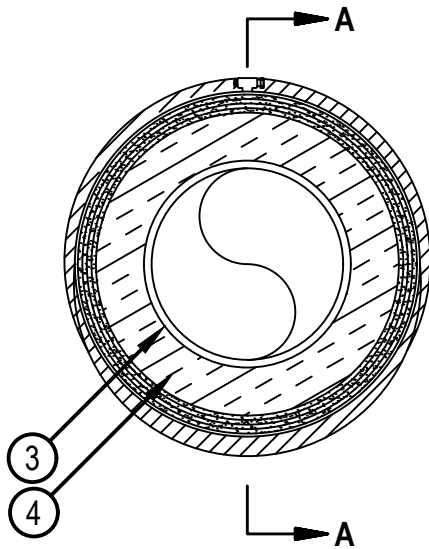

1. Wall Assembly — The 1 and 2 hr fire-rated gypsum board/stud wall assembly shall be constructed of the materials and in the manner described in the individual U300, U400, V400 or W400 Series Wall and Partition Design in the UL Fire Resistance Directory and shall include the following construction features:
  - A. Studs — Wall framing may consist of either wood studs or steel channel studs. Wood studs to consist of nom 2 by 4 in. (51 by 102 mm) lumber spaced 16 in. (406 mm) OC. Steel studs to be min 3-1/2 in. (89 mm) wide and spaced max 24 in. (610 mm) OC.
  - B. Gypsum Board\* — The gypsum board type, thickness, number of layers, fastener type and sheet orientation shall be as specified in the individual Wall and Partition Design in the UL Fire Resistance Directory. Max diam of opening is 14 in. (356 mm).  
The hourly F Rating of the firestop system is equal to the hourly fire rating of the wall assembly in which it is installed.
2. Steel Sleeve — Nom 13-1/2 in. (343 mm) diam cylindrical sleeve fabricated from min 0.016 in. (0.40 mm) thick (28 gauge) galv sheet steel with min 1 in. (25 mm) overlap at the longitudinal seam. Sleeve to extend nom 2 in. (51 mm) beyond each surface of the wall assembly. The sleeve shall be compressed around the insulated pipe (Item 3) and wrap strip (Item 5A) using min 1/2 in. (13 mm) wide stainless steel band clamps fastened at the center of wrap strip. The annular space between the sleeve and periphery of opening shall be min 0 in. (point contact) to max 1/2 in. (13 mm).



Reproduced by HILTI, Inc. Courtesy of  
Underwriters Laboratories, Inc.  
November 15, 2021

3. Through Penetrants — One nonmetallic pipe to be installed concentrically within the steel sleeve (Item 2). Pipe to be rigidly supported on both sides of wall assembly. The following types and sizes of nonmetallic pipes may be used:
- A. Polypropylene (PP-R) Pipe — Nom 8 in. (200 mm OD) diam (or smaller) Aquatherm Bluepipe SDR11 PP-R pipe for use in closed (process or supply) piping systems.
  - 4. Pipe Covering\* — Cellular Glass Insulation — Nom 2 in. (51 mm) thick cellular glass units sized to the outside diam of the pipe and supplied in nom 24 in. (610 mm) long half sections or nom 18 in. (457 mm) long segments. The hourly T Rating of the firestop system is equal to the hourly fire rating of the wall assembly in which it is installed when this pipe covering is used.
  - 4A. Sheathing Material\* — Foil-scrim-kraft or all service jacket material shall be wrapped around the outer circumference of the pipe insulation (Item 4) with the kraft side exposed. Longitudinal joints and transverse joints sealed with metal fasteners or butt tape.  
See Sheathing Materials (BVDV) category in the Building Materials Directory for names of manufacturers. Any sheathing material meeting the above specifications and bearing the UL Classification Marking with a Flame Spread Index of 25 or less and a Smoke Developed Index of 50 or less may be used.
  - 4B. Pipe Covering\* — As an alternate to the pipe covering in Item 4, nom 1 in. (25 mm) thick hollow cylindrical heavy density (min 3.5 pcf or 56 kg/m<sup>3</sup>) glass fiber units jacketed on the outside with an all service jacket may be used. Longitudinal joints sealed with metal fasteners or factory-applied self-sealing lap tape. Transverse joints secured with metal fasteners or with butt tape supplied with the product. When this pipe covering is used, the hourly T Rating of the firestop system is equal to 0 hr when installed in a 1 hr fire rated wall assembly, and the T Rating is 1 hr when installed in a 2 hr fire rated wall assembly.  
See Pipe and Equipment Covering — Materials (BRGU) category in the Building Materials Directory for names of manufacturers. Any pipe covering material meeting the above specifications and bearing the UL Classification Marking with a Flame Spread Index of 25 or less and a Smoke Developed Index of 50 or less may be used.
5. Firestop System — The firestop system shall consist of the following:
- A. Fill, Void or Cavity Material\* — Wrap Strip — Nom 3/16 in. (5 mm) thick by 1-3/4 in. (44 mm) wide intumescent wrap strip. Four layers of wrap strip are continuously wrapped around the insulated through-penetrant with ends butted and held in place with tape. Wrap strip is installed within the steel sleeve at each side of wall, flush with ends of sleeve.  
HILTI CONSTRUCTION CHEMICALS, DIV OF HILTI INC — CP648-E W45/1-3/4" Firestop Wrap Strip
  - B. Fill, Void or Cavity Materials\* — Sealant — Min 1/2 in. (13 mm) thickness of fill material applied within the annulus between sleeve and opening, flush with both surfaces of wall. In addition, a min 1/2 in. (13 mm) bead of sealant shall be applied at the point contact location between sleeve and opening.  
HILTI CONSTRUCTION CHEMICALS, DIV OF HILTI INC — FS-ONE MAX Intumescent Sealant

\* Indicates such products shall bear the UL or cUL Certification Mark for jurisdictions employing the UL or cUL Certification (such as Canada), respectively.