



Classified by  
Underwriters Laboratories, Inc.  
to UL 1479 and CAN/ULC-S115

# System No. W-L-7155

WL 7155

ANSI/UL1479 (ASTM E814)	CAN/ULC S115
F Ratings — 1 and 2 Hr (See Item 1)	F Ratings — 1 and 2 Hr (See Item 1)
T Ratings — 0 Hr	FT Ratings — 0 Hr
L Rating at Ambient — Less Than 1 CFM/sq ft	FH Ratings — 1 and 2 Hr (See Item 1)
L Rating at 400 F — Less Than 1 CFM/sq ft	FTH Ratings — 0 Hr
	L Rating at Ambient — Less Than 1 CFM/sq ft
	L Rating at 400 F — Less Than 1 CFM/sq ft

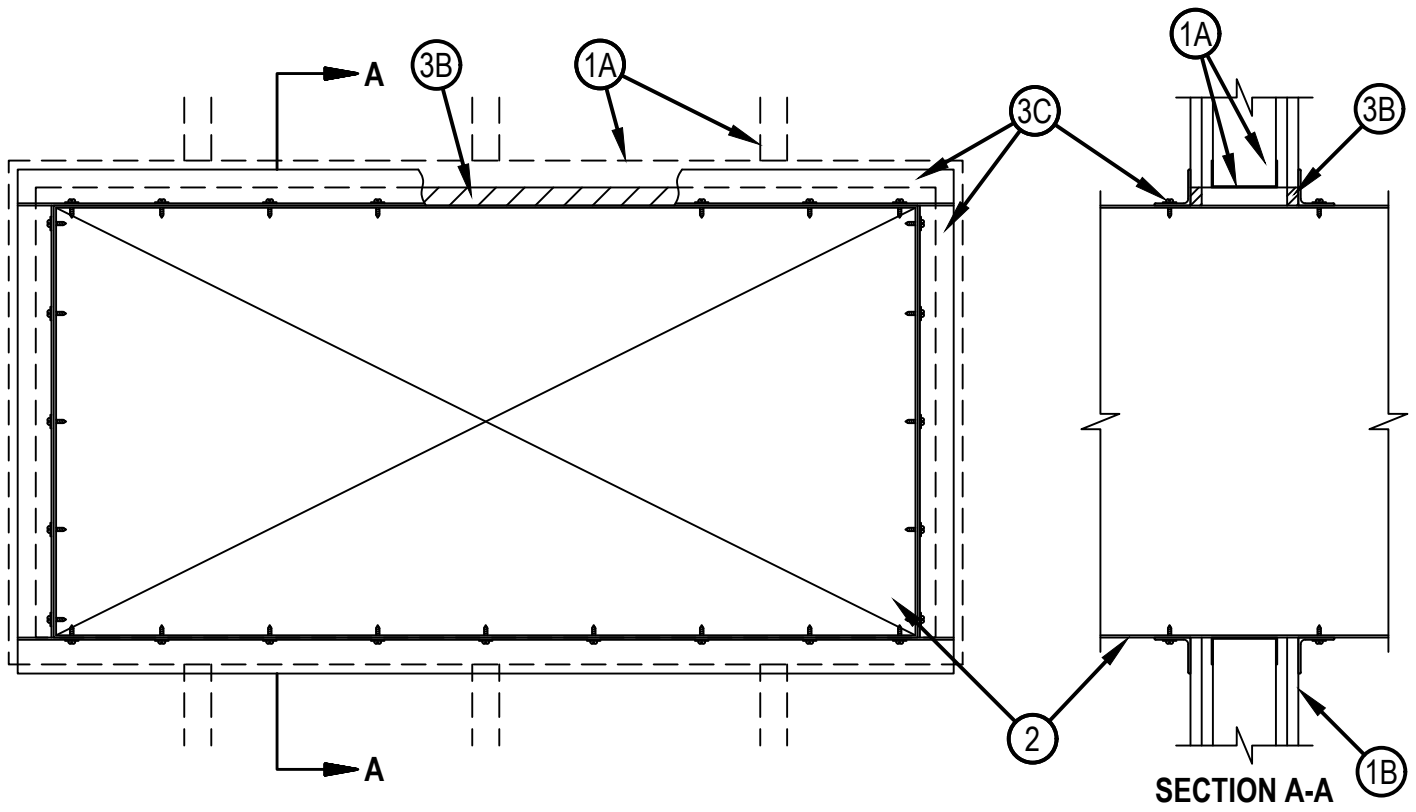

1. Wall Assembly — The 1 or 2 hr fire-rated gypsum wallboard/stud wall assembly shall be constructed of the materials and in the manner described in the individual U400, V400 or W400 Series Wall or Partition Design in the UL Fire Resistance Directory and shall include the following construction features:

- A. Studs — Wall framing shall consist of min 3-1/2 in. (89 mm) wide steel channel studs spaced max 24 in. (610 mm) OC. Additional steel studs shall be used to completely frame the opening.
- B. Gypsum Board\* — 5/8 in. (16 mm) thick, 4 ft (1.22 m) wide with square or tapered edges. The gypsum board type, thickness, number of layers, fastener type and sheet orientation shall be as specified in the individual Wall and Partition Design in the UL Fire Resistance Directory. Max area of opening is 73.7 sq ft (6.85 m<sup>2</sup>) with a max dimension of 104 in. (2.64 m).

The hourly F and FH Ratings of the firestop system are equal to the hourly fire rating of the wall assembly in which it is installed.

2. Steel Duct — Max 100 in. by 100 in. (2.5 by 2.5 m) galv steel duct to be installed either concentrically or eccentrically within the firestop system. The duct shall be constructed and reinforced in accordance with SMACNA construction standards. The space between the steel duct and periphery of opening shall be min 0 in. (point contact) to max 2 in. (51 mm). Steel duct to be rigidly supported on both sides of the wall assembly.



**Hilti Firestop Systems**

Reproduced by HILTI, Inc. Courtesy of  
Underwriters Laboratories, Inc.  
December 26, 2017

# System No. W-L-7155

WL 7155

2A1. Through-Penetrating Product\* — As an alternate to Item 2. Fiber cement with galvanized steel facing, 3/8 in. (10 mm) thick composite metallic duct, with a max cross-sectional area of 43.0 sq ft, (4 m<sup>2</sup>) and a max individual dimension of 78 3/4 in. (2 m). Duct to be installed either concentrically or eccentrically within the firestop system such that the annular space is min 0 in. (point contact) to max 2 in. (51 mm). Duct to be rigidly supported on both sides of wall assembly. Refer to Ventilation Duct Assemblies in Vol. 2 of the Fire Resistance Directory.

DURASYSTEMS BARRIERS INC — Type DuraDuct HP.

2A2. Through-Penetrating Product\* — As an alternate to Item 2. Fiber cement with galvanized steel facing, 1/4 in. (6 mm) thick, with a max cross-sectional area of 1764 sq in. (1.14 m<sup>2</sup>), and a max individual dimension of 42 in. (1067 mm). Duct to be installed either concentrically or eccentrically within the firestop system such that the annular space is min 0 in. (point contact) to max 2 in. (51 mm). Duct to be rigidly supported on both sides of wall assembly and installed in accordance. Refer to Ventilation Duct Assemblies in Vol. 2 of the Fire Resistance Directory.

DURASYSTEMS BARRIERS INC — Type DuraDuct SD.

2A3. Through-Penetrating Product\* — As an alternate to Item 2. Galvanized steel faced duct panel, with a max cross-sectional area of 2450 sq in. (1.58 m<sup>2</sup>), and a max individual dimension of 49-1/2 in. (1258 mm) Duct to be installed either concentrically or eccentrically within the firestop system such that the annular space is min 0 in. (point contact) to max 2 in. (51 mm). Duct to be rigidly supported on both sides wall assembly. Refer to Ventilation Duct Assemblies in Vol. 2 of the Fire Resistance Directory.

DURASYSTEMS BARRIERS INC — Type DuraDuct GNX.

3 Firestop System — The firestop system shall consist of the following:

A. Packing Material — (Optional, Not Shown) — Polyethylene backer rod, mineral wool batt insulation or fiberglass batt insulation friction fitted into annular space. Packing material to be recessed from both surfaces of wall to accommodate the required thickness of fill material.

A1. Packing Material — Required as specified in Table below. Min 3-3/4 in. (95 mm) or 5 in. (127 mm) thickness of min 4 pcf (64 kg/m<sup>3</sup>) mineral wool batt insulation firmly packed into opening as a permanent form for 1 and 2 hr rated assemblies, respectively. Packing material to be recessed from both surfaces of wall to accommodate the required thickness of fill material.

B. Fill, Void or Cavity Material\* — Sealant — Min 5/8 in. (16 mm) thickness of fill material applied within the annulus, flush with both surfaces of wall. Min 1/4 in. (6 mm) diam bead of fill material shall be applied at the point contact location between the steel duct and the gypsum board.

HILTI CONSTRUCTION CHEMICALS, DIV OF HILTI INC — CFS-S SIL GG Sealant, FS-ONE Sealant, FS-ONE MAX Intumescent Sealant or CP606 Flexible Firestop Sealant

C. Steel Retaining Angles — Min No. 16 gauge galv steel angles sized to lap steel duct a min of 2 in. (51 mm) and to lap wall surfaces a min of 1 in. (25 mm). When max duct dimension does not exceed 48 in. (122 cm) and duct area does not exceed 1300 in<sup>2</sup> (8387 cm<sup>2</sup>), angles may be min No. 18 gauge galv steel. Angles attached to steel duct on both sides of wall with min No. 10 by 1/2 in. (13 mm) long steel sheet metal screws located a max of 1 in. (25 mm) from each end of steel duct and spaced a max of 6 in. (152 mm) OC. Steel angles are optional for those sides of duct that do not exceed the dimension specified in Table below, dependent on packing material, sealant and annular space as specified.

Max Duct Dimension	Duct Thickness	Annular Space	Packing Material	Angle (Item 3C) Required
24 in. (610 mm)	24 ga or heavier	1/2 in. min to 1 in. max (13 to 25 mm)	Item 3A1	No

\* Indicates such products shall bear the UL or cUL Certification Mark for jurisdictions employing the UL or cUL Certification (such as Canada), respectively.

