



Classified by
Underwriters Laboratories, Inc.
to UL 1479 and CAN/ULC-S115

System No. W-L-8035

ANSI/UL1479 (ASTM E814)	CAN/ULC S115
F Ratings — 1 and 2 Hr (See Item 1)	F Ratings — 1 and 2 Hr (See Item 1)
T Ratings — 1, 1-1/2 and 2 Hr (See Item 2)	FT Ratings — 1, 1-1/2 and 2 Hr (See Item 2)
	FH Ratings — 1 and 2 Hr (See Item 1)
	FTH Ratings — 1, 1-1/2 and 2 Hr (See Item 2)

WL 8035

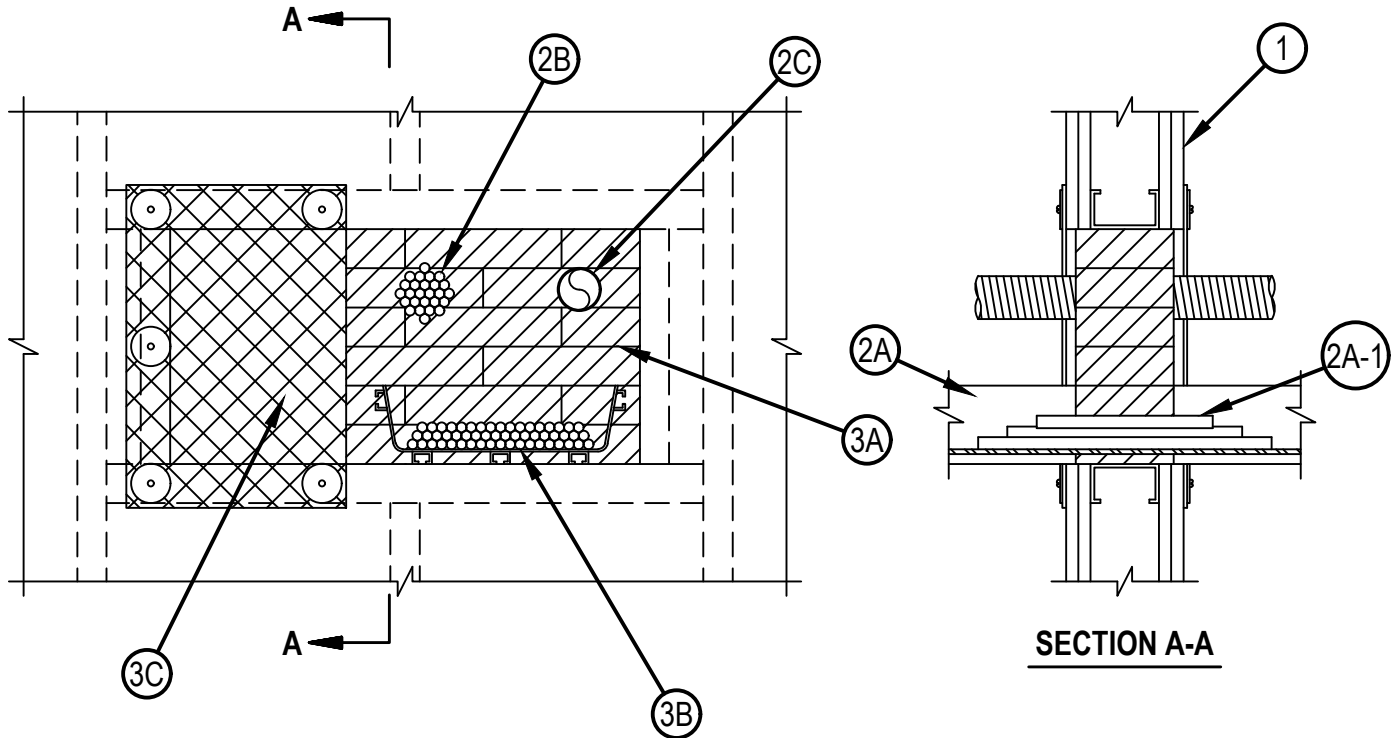

1. Wall Assembly — The 1 or 2 hr fire rated gypsum board/stud wall assembly shall be constructed of the materials and in the manner specified if the individual U300, U400, V400 or W400 Series Wall and Partition Designs in the Fire Resistance Directory and shall include the following construction features:
 - A. Studs — Wall framing shall consist of either wood studs or channel shaped steel studs. Wood studs to consist of 2 by 4 in. (51 by 102 mm) lumber spaced 16 in. (406 mm) OC. Steel studs to be min 2-1/2 in. (64 mm) wide, fabricated from min 25 MSG galvanized steel, spaced max 24 in. (610 mm) OC. Additional framing member shall be used to completely frame around opening.
 - B. Gypsum Board* — Nom 5/8 in. (16 mm) thick with square or tapered edges. The gypsum board type, number of layers and sheet orientation shall be as specified in the individual Wall and Partition Design Number. Max area of opening is 288 sq in. (1858 cm²) with max dimension of 24 in. (610 mm).

The hourly F and FH Ratings of the firestop system is are equal to the hourly fire rating of the wall assembly in which it is installed.
2. Through Penetrants — Max three of the following penetrants, limited to one of each type in any combination:
 - A. Optical Fiber/Communications Cable Raceways+ — Max 12 in. (305 mm) wide by 4 in. (102 mm) deep communications cable raceway and optional cover plate, formed from Acrylonitrile Butadiene Styrene (ABS). The annular space between the cable raceway and the periphery of the opening shall be min 0 in. (point contact) to max 12 in. (305 mm). Raceway to be rigidly supported on both sides of wall assembly. The minimum space between adjacent penetrants shall be 3-1/2 in. (89 mm).
 - A1. Fiber Optic Cables — Multiple fiber communication cable jacketed on the outside with polyvinyl chloride (PVC) and having a max outside diam of 1/2 in. (13 mm). Aggregate cross-sectional area of cables in raceway not to exceed 40 percent of the cross-sectional area of the raceway.



Hilti Firestop Systems

Reproduced by HILTI, Inc. Courtesy of
Underwriters Laboratories, Inc.
January 25, 2016

System No. W-L-8035

WL 8035

B. Cables — Max 3 in. (76 mm) diam tightly bundled cable bundle. The annular space between the cable bundle and the periphery of the opening shall be minimum 1-3/4 in. (44 mm). The min space between adjacent penetrants shall be 3-1/2 in. (89 mm). Raceway to be rigidly supported on both sides of wall assembly. Cable bundle may be any combination of the following types and sizes of cables:

1. Max 100 pair No. 24 AWG copper telephone cables with polyvinyl (PVC) insulation and jacket materials.
2. Max 7/C No. 12 AWG cable with PVC insulation and jacket materials.
3. Multiple fiber optical communication cables with PVC jacket material and having a max outside diameter of 1/2 in. (13 mm).

C. Optical Fiber/Communication Cable Raceways+ — Nom 2 in. (51 mm) diam (or smaller) optical fiber raceway, formed from polyvinyl chloride (PVC). Raceway to be installed in accordance with the National Electrical Code (NFPA No. 70). The annular space between the raceway and the periphery of the opening shall be minimum 2 in. (51 mm). The minimum space between adjacent penetrants shall be 3-1/2 in. (89 mm). Raceway to be rigidly supported on both sides of wall assembly.

See Optical Fiber/Communication Cable Raceways (QAZM) category in the Electrical Construction Materials Directory for names of manufacturers.

The T Rating of the firestop system is dependent upon the type of cable or penetrant within the firestop system as shown in the following table:

Type of Penetrant	T, FT and FTH Ratings, Hr
A	2
A1	2
B1	1/2
B2	1
B3	1-1/2
C	2

3. Firestop System — The firestop system shall consist of the following:

A. Fill, Void or Cavity Material* - Fire blocks — For walls incorporating max 3-5/8 in. (92 mm) steel studs or max 2 by 4 in. (51 by 102 mm) wood studs, fire block installed with 5 in. (127 mm) dimension projecting through and centered in opening. For walls constructed of larger steel or wood studs, fire block installed with long dimension passing through and centered in opening. Blocks may or may not be cut flush with both surfaces of wall. When multiple layers of gypsum board are used, blocks may be recessed 1/2 in. (13 mm) from surface of wall. When optional cover plate is used with communications cable raceway, blocks shall be placed within the raceway at the point of the penetration to fully fill the void between cables and cover plate. Blocks firmly packed within opening. Either one or a combination of the block types specified below may be used.

HILTI CONSTRUCTION CHEMICALS, DIV OF HILTI INC — FS657 Fire Block or CFS-BL Firestop Block

B. Fill, Void or Cavity Material* — Fill material to be forced into interstices of cables, between cables and cable tray and in obvious openings between blocks and between blocks and the periphery of the opening to the max extent possible on both surfaces of wall.

HILTI CONSTRUCTION CHEMICALS, DIV OF HILTI INC — FS-ONE Sealant, FS-ONE MAX Intumescent Sealant, CP618 Firestop Putty Stick, CP 660 Firestop Foam or CP 620 Fire Foam

C. Wire Mesh — When the annular space exceeds 4 in. (102 mm) to the periphery of opening, a nom 2 by 2 in. (51 by 51 mm) wire fencing shall be used to keep the blocks in place. The wire fencing shall be fabricated from min No. 16 SWG (0.060 in. or 1.5 mm) galv steel wire. The wire mesh shall begin 2-1/2 in. (64 mm) from the penetrant and overlap min 3 in. (76 mm) beyond the periphery of the opening. Wire fencing secured to both surfaces of the wall assembly by means of 1/4 in. (6 mm) diam long hollow wall anchors and 1/2 in. (13 mm) by 1-1/2 in. (38 mm) diam fender washers spaced max 8 in. (203 mm) OC or attached to steel studs with steel screws and 1-1/2 in. (38 mm) diam steel washers spaced max 6 in. (152 mm) OC.

* Indicates such products shall bear the UL or cUL Certification Mark for jurisdictions employing the UL or cUL Certification (such as Canada), respectively.

+Bearing the UL Listing Mark



Hilti Firestop Systems

Reproduced by HILTI, Inc. Courtesy of
Underwriters Laboratories, Inc.
January 25, 2016