

UL/cUL SYSTEM NO. W-J-3260

CABLE BUNDLE THROUGH CONCRETE WALL ASSEMBLY

F-RATING = 2-HR.

T-RATING = 2-HR.

L-RATING AT AMBIENT = 1 CFM / SQ FT OR LESS

L-RATING AT 400°F = 1 CFM / SQ FT OR LESS

WJ3260b.050820

FRONT VIEW

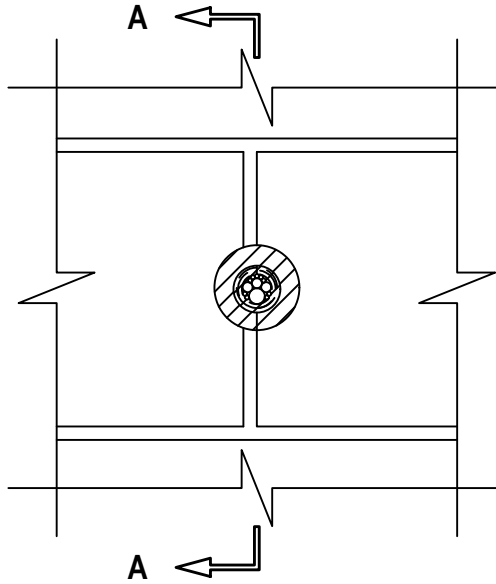

SECTION A-A

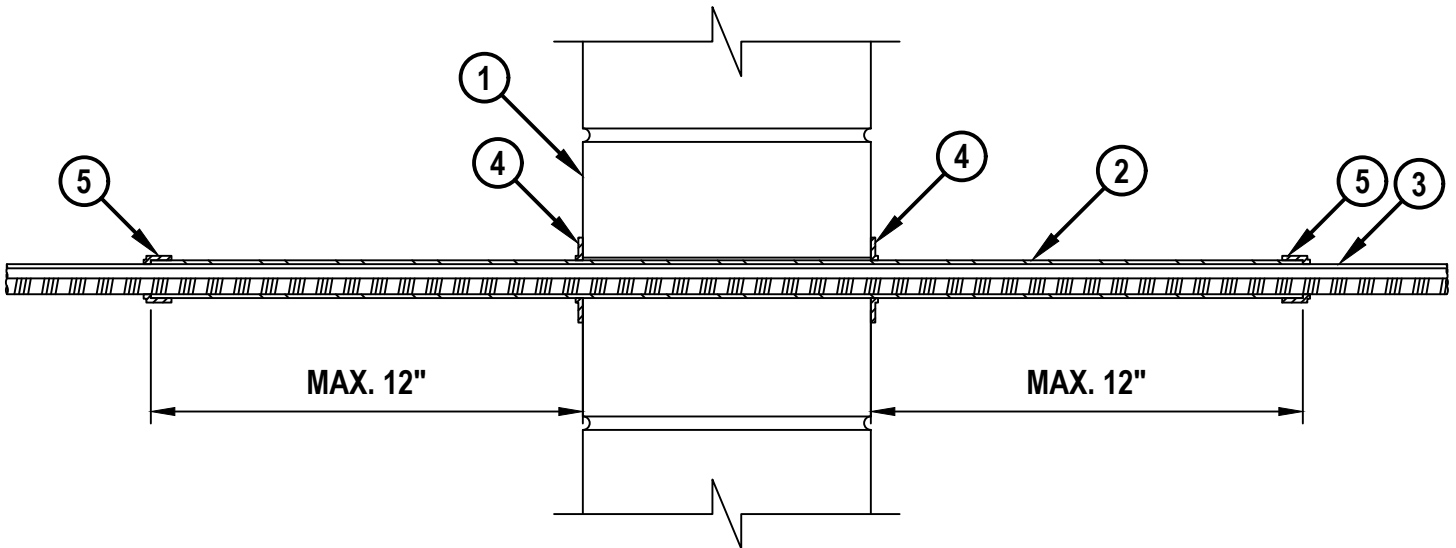

1. CONCRETE WALL ASSEMBLY (2-HR. FIRE-RATING) :

A. LIGHTWEIGHT OR NORMAL WEIGHT CONCRETE WALL (MINIMUM 6" THICK).

B. ANY UL/cUL CLASSIFIED CONCRETE BLOCK WALL.



HILTI, Inc.
Plano, Texas USA (800) 879-8000

Sheet	1 of 2
Scale	3/16" = 1"
Date	May 08, 2020

Drawing No.

WJ
3260b

Saving Lives through Innovation and Education

CABLE BUNDLE THROUGH CONCRETE WALL ASSEMBLY

F-RATING = 1-HR. OR 2-HR.

T-RATING = 1-HR. OR 2-HR.

L-RATING AT AMBIENT = 1 CFM / SQ FT OR LESS

L-RATING AT 400°F = 1 CFM / SQ FT OR LESS

WJ3260b.050820

2. MAXIMUM 1" NOMINAL DIAMETER STEEL CONDUIT SLEEVE. SLEEVE MAY BE INSTALLED FLUSH WITH BOTH WALL SURFACES OR EXTEND MAXIMUM 12" BEYOND ONE OR BOTH WALL SURFACES. SLEEVE MAY ALSO EXTEND CONTINUOUSLY BEYOND ONE WALL SURFACE. SLEEVE SHALL BE SUPPORTED ON THOSE SIDES OF THE WALL WHERE THE SLEEVE EXTENDS. AS AN OPTION, THE SLEEVE MAY BE PROVIDED WITH A PLASTIC GROMMET AT THE SLEEVE END.
3. SINGLE CABLE OR CABLE BUNDLE TO BE ONE OR A COMBINATION OF ANY OF THE FOLLOWING :
 - A. MAXIMUM 3/C NO. 8 AWG NM COPPER CONDUCTOR (ROMEX) CABLE WITH PVC INSULATION AND JACKET.
 - B. MAXIMUM 7/C NO. 12 AWG COPPER CONDUCTOR CONTROL CABLE WITH PVC OR XLPE JACKET AND INSULATION.
 - C. MAXIMUM 100 PAIR NO. 24 AWG COPPER CONDUCTOR TELECOMMUNICATION CABLE WITH PVC OR PLENUM RATED INSULATION AND JACKETING.
 - D. MAXIMUM 4 PAIR NO. 22 AWG CAT 5 OR 6 COMPUTER CABLE WITH PVC OR PLENUM RATED INSULATION AND JACKETING.
 - E. MAXIMUM RG 6/U COAXIAL CABLE WITH FLUORINATED ETHYLENE OR PVC INSULATION AND JACKETING (MAXIMUM 1/2" DIAMETER).
 - F. MAXIMUM 24 FIBER-OPTIC CABLE WITH PVC OR PE JACKET AND INSULATION.
 - G. MAXIMUM 2/C NO. 18 AWG COPPER CONDUCTOR FIRE ALARM CABLE WITH OR WITHOUT A JACKET UNDER A METAL ARMOR (AFC CABLE SYSTEMS, INC).
 - H. MAXIMUM 3/C NO. 10 AWG COPPER CONDUCTOR METAL CLAD CABLE.
4. HILTI CFS-D 1" FIRESTOP PUTTY DISC PRESSED FIRMLY AROUND THE SLEEVE LAPPING NOMINAL 5mm ONTO SLEEVE AND FIRMLY PRESSED TO LAP ONTO THE WALL. DISC SEAM TO BE FIRMLY PRESSED AND SEALED TIGHT.
5. HILTI CFS-D 1" FIRESTOP PUTTY DISC PRESSED FIRMLY AROUND THE CABLE/CABLE BUNDLE, AT EXIT FROM EACH SLEEVE, LAPPING NOMINAL 5mm ONTO CABLES TO COMPLETELY COVER OPENING AND FIRMLY PRESSED TO LAP ONTO THE SLEEVE. DISC SEAM TO BE FIRMLY PRESSED AND SEALED TIGHT.

NOTES : 1. OPENING MAY BE ROUND, RECTANGULAR, OR IRREGULAR WITH A MAXIMUM DIAMETER OR DIMENSION OF OPENING = 1-1/8".

2. CABLES MAY REPRESENT 0% TO 100% OF VISUAL FILL OF SLEEVE.

3. ANNULAR SPACE BETWEEN SLEEVE AND PERIPHERY OF OPENING = MINIMUM 0", MAXIMUM 1/8".

4. [NOT SHOWN] AS AN ALTERNATE TO ITEM 4 ABOVE, INSTALL MINIMUM 1/2" BEAD HILTI FS-ONE MAX INTUMESCENT FIRESTOP SEALANT OR HILTI CP 606 FLEXIBLE FIRESTOP SEALANT AT THE SLEEVE/WALL INTERFACE.



HILTI, Inc.
Plano, Texas USA (800) 879-8000

Sheet	2 of 2
Scale	-
Date	May 08, 2020

Drawing No.
WJ
3260b